

# M6800 Microcomputer System Support Products



MOTOROLA MICROSYSTEMS

# Motorola M6800 Support Products

## For Total Microcomputer System Design

The evolution of large-scale integration (LSI) has spawned the microprocessor as a low-cost circuit component, and has created a viable alternative to the conventional hardwired method of circuit, and system design. The resultant concept of utilizing a programmable microcomputer to perform control functions previously relegated to dedicated, single-function circuitry presents such a powerful approach to the implementation of control systems that it is widely acclaimed as the single most important development of the past decade.

To facilitate the design of pervasive and cost-effective microcomputer-based systems, Motorola has generated a repertoire of basic LSI building blocks. Appropriate combination of these components permits the establishment of an end-system with any desired degree of sophistication. Known as the M6800 Microcomputer Family, this repertoire at present includes the following components:

**MC6800** – A Microprocessing Unit (MPU) which represents the heart of a microcomputer system. Encompassed within this component are the arithmetic and control capabilities that are fundamental to any computer system.

**MC6820** – A Peripheral Interface Adapter (PIA) that interfaces the MPU with a variety of input/output peripherals such as terminals, printers, etc. Its parallel I/O architecture interfaces with a parallel oriented peripheral.

**MC6850** – An Asynchronous Communications Interface Adapter (ACIA) for communications between the MPU and a serially oriented peripheral, such as a Modem. This converts serially transmitted data to the parallel orientation required by the MPU, and vice versa.

**MC6852** – A Synchronous Serial Data Adapter (SSDA) for communications between the MPU and a bit-serial peripheral.

**MC6860** – A low-speed Modem (modulator-demodulator) that permits the MPU to be accessed, through the ACIA, by data transmitted over the telephone lines.

**MCM6830** – A 1024 x 8-bit Read-Only Memory (ROM), programmed by the factory with the appropriate instructions stipulated by the designer's end-system requirements.

**MCM6810** – A 128 x 8-bit Random Access Memory (RAM) with access time as low as 350 ns (MC6810AL1).

All of the above parts are mutually compatible in a bus-oriented system that requires no additional buffers or other outboard components. An advanced N-channel MOS technology yields reliable operation while a powerful 72-statement instruction set provides a high degree of programming flexibility.

But successful microcomputer-based system design requires more than a set of compatible "hardware" components. Even after a "working computer" has been implemented through the interconnection of the required components, there still remains the development and verification of the "program" that converts a mindless computer into a dedicated functional system. The M6800 system, therefore, comprises an extensive and growing array of support products dedicated to insuring the timely and successful completion of a design effort.

### *The Support Products*

*Motorola's total M6800 System Design Support concept encompasses the following categories:*

**Support Hardware** – A series of instruments that emulate, demonstrate and evaluate the operation of any M6800-based design.

**Support Peripherals** – A growing array of peripheral equipment that interfaces with M6800 system designs to increase data throughput during system development.

**Support Software** – Development and diagnostic programs that permit the design of end-use programs utilizing Time-Share computers, in-house computers or the support hardware mentioned above.

**Design Support** – Includes documentation, training, applications assistance and a staff of professionals to answer questions and help solve system development problems.

*The information to follow describes, in detail, these support products.*



**MOTOROLA MICROSYSTEMS**

ISSUE A  
©MOTOROLA INC., 1976

# M6800 Microcomputer System Support Products

## CONTENTS

### SUPPORT HARDWARE

M68SDT EXORciser (including resident modules)

Optional Modules:

MEX6812-1	2K Static RAM Module
MEX6816-1	16K Dynamic RAM Module
MEX6820	Input/Ouptut Module (including MEX68IC Interconnection Cables)
MEX6850	ACIA Module
*MEX68CT	MOTEST Component Tester
MEX68PP1	PROM Programmer Module
MEX68RR	EROM/RAM Module
MEX68SA	Systems Analyzer Module
MEX68USE	User System Evaluator
MEX68WW	Wirewrap Module
MEX68XT	Extender Module

M6800B Evaluation Module II

### SUPPORT PERIPHERALS

EXORdisk — M68FD3602

EXORtape — M68R680

### SUPPORT SOFTWARE

Resident Software

Co-Resident Editor and Assembler

M68ASMR020 Resident Macro Assembler and Linking Editor

M68FTNR010D Resident FORTRAN Compiler

Software for In-House Computers

M68SAM Cross Assembler

M68MPL Compiler

M68EML Simulator

Time-Sharing Systems Software

### DESIGN SUPPORT

Documentation, Training, and Applications Assistance

\*Data Sheet Available Soon.

 **MOTOROLA MICROSYSTEMS**

Motorola has introduced a series of products to aid in the development of microprocessor systems. These products not only simplify breadboarding of an M6800-based microcomputer system, but also provide an efficient and economical means of evaluating, monitoring, and troubleshooting the system and evaluating and testing the M6800 family of LSI parts being used in the system.



# M6800

## Support Hardware



**M68SDT  
EXORciser  
Emulator for M6800  
Based Systems**

# M68SDT EXORciser Emulator for M6800 Based Systems

The EXORciser is a modularized, expandable instrument that permits "instant breadboarding" and evaluation of any M6800-based microcomputer system. It consists of a prewired, bus-oriented chassis and power supply, together with three basic modules — an MPU Module, a Debug Module and a Baud Rate Module. These provide the basic control and interface functions of a microcomputer, and house the system development and diagnostic programs. A number of separately available, optional memory modules and additional interface modules (up to twelve) may be added, simply by plugging them into existing prewired sockets, to convert the basic system into an exact prototype of a desired end system. Thus, the EXORciser, with its built-in EXbug Firmware, enables the designer to configure, evaluate and debug his final system hardware and software using actual M6800 components.

## Features

- Reduces system development time and cost
- Emulates final system architecture and performance through modular building block concept with standard M6800 components
- Permits debugging of final system design through built-in diagnostic firmware
- Facilitates program development using separately available Resident Software

## EXORciser Options

### Basic Models:

M68SDTT1	110 Volt Table Top EXORciser
M68SDTT2	220 Volt Table Top EXORciser
M68SDTTU1	110 Volt Table Top EXORciser with USE
M68SDTTU2	220 Volt Table Top EXORciser with USE
(Dimensions:	19.25 x 17.5 x 7, W x D x H)
MEX68RK	Rack Mounted Conversion Kit
	(Converts standard table-top model for rack mounting.)

### Optional Assemblies:

MEX6800	MPU Module (additional module)
MEX6812-1	2K Static RAM Module
MEX6815	8K Dynamic RAM Module
MEX6816-1	16K Dynamic RAM Module
MEX6820	Input/Output Module
MEX6850	ACIA Module
MEX68CT	MOTEST (Component Tester)
MEX68IC	Input/Output Flatribbon Interconnect Cable (Two per Input/Output Module)
MEX68PP	PROM Programmer Module
MEX68RR	EROM/RAM Module
MEX68SA	Systems Analyzer
MEX68USE	USE (User's System Evaluator)
MEX68WW	Wirewrap Module
MEX68XT	Extender Module

### Support Software Programs:

M68ASMR021D	Resident Macro Assembler and Linking Loader on Diskette
M68XAE6812A	Resident Assembler/Editor on Cassette
M68XAE6812B	Resident Assembler/Editor on Paper Tape
M68XAE6812D	Resident Assembler/Editor on Diskette

## EXORciser Specifications

Power Requirements	95-135/205-250 Vac 47-420 Hz 250 W
Word Size	
Data	8 Bits
Address	16 Bits
Instruction	8, 16, and 24 Bits
Memory Capability	65,536 bytes (maximum)
Instructions	72, variable length
Clock Cycle Time	Selectable: 1 $\mu$ s crystal control clock or provisions for an external clock between 1 $\mu$ s and 10 $\mu$ s.
Interrupt	Maskable real-time
Data Terminal Interface Characteristics	
Baud Rates	110, 150, 300, 600, 1200, 2400, 4800 and 9600
(Switch Selectable)	
Signal Characteristics	TTY (20 mA neutral current loop) or EIA RS-232C compatible
Reader Control Signal	Control signal for TTY devices modified for external control
Operating Temperature	0-55°C

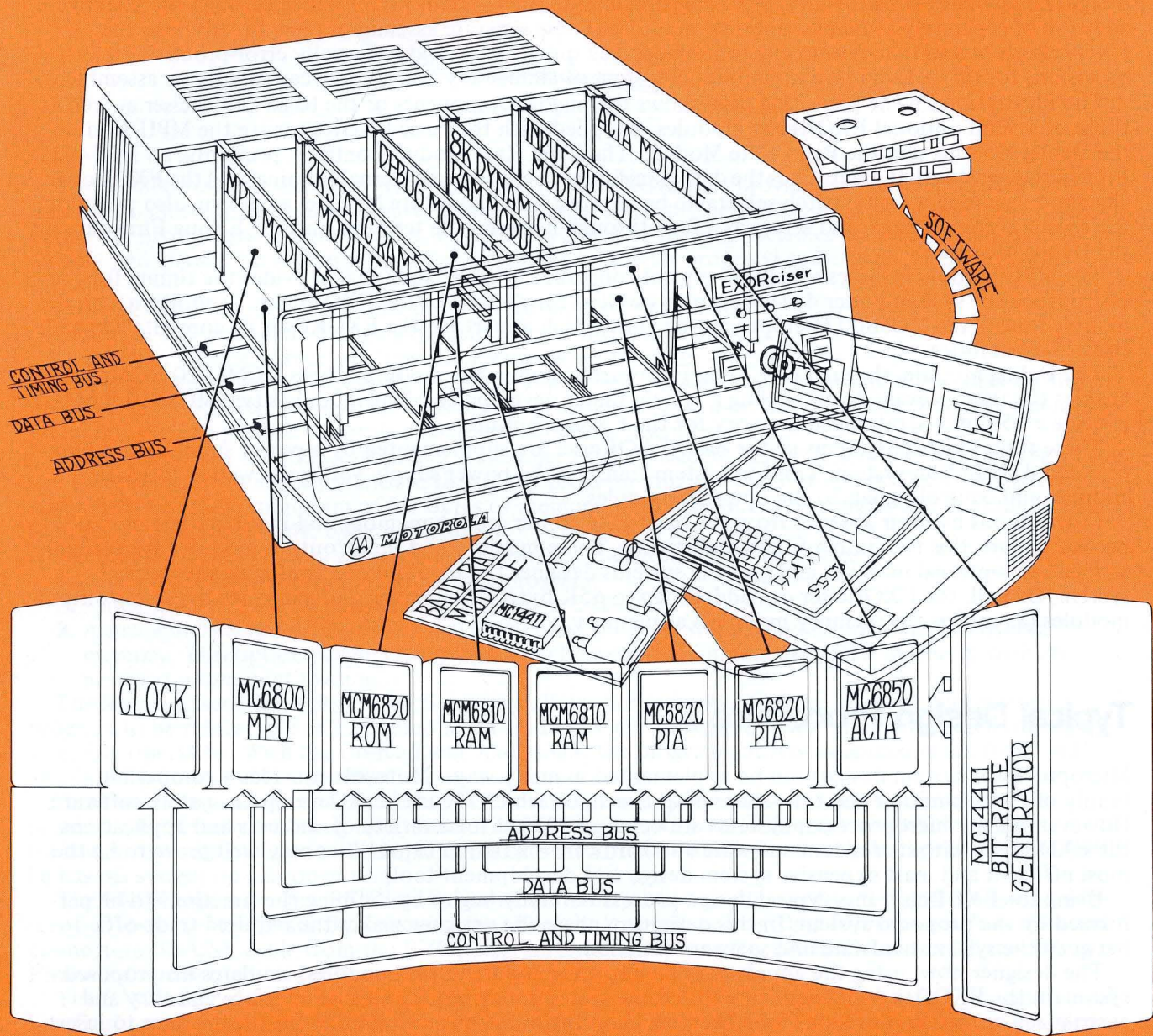

# The M68SDT EXORciser

## Description and Operation

The basic EXORciser contains the common ingredients of a microcomputer and offers the system designer a low-cost, versatile means of achieving unique final-system performance through the selective addition of separately available, optional modules. These separate assemblies plug directly into the EXORciser's bus so that system expansion becomes quick, easy, and essentially error-proof. With provisions for up to 12 add-on assemblies, a system of almost any complexity can rapidly be assembled.

The illustration on the preceding page shows the major components of the basic EXORciser as well as those of several optional EXORciser modules. Supplied with the basic EXORciser are the MPU Module, the Debug Module, and the Baud Rate Module. The Baud Rate Module contains, primarily, an MC14411 Bit Rate Generator that determines the data transfer rate between an external terminal and the EXORciser. The module supplies eight switch selectable baud rates. The Baud Rate Module, as shown, also provides the terminal connections, and serves as a feed-through between the terminal and the EXbug Firmware on the Debug Module.

The MPU Module includes a built-in, crystal-controlled 1 MHz clock that provides the timing for the microprocessor system under development, as well as for the rest of the EXORciser. In addition, this module houses the MC6800 Microprocessing Unit which imparts to the EXORciser its computation and control capabilities.

The Debug Module, through its EXbug Firmware stored in the module's three MCM6830 ROMs, enables the user to evaluate and debug a system under development. The module's two MC6810 RAMs provide a 256 byte scratch-pad memory for the EXbug routines.

These functional subsystems of the basic EXORciser are supplemented by a power supply and a bus-oriented distribution system. This bus system transfers the power supply voltage as well as the data, address, and control signals to the optional modules.

Conspicuous by their absence from the basic EXORciser are the memory and input/output modules needed to turn this tool into a functional system. These memory and input/output modules are available as separate, optional modules and give the systems designer the flexibility to configure any desired system. Overall, the EXORciser can address up to 65K bytes of memory, and addresses the input/output modules (as well as the memory modules) as memory.

## Typical Design Procedure

Microprocessor system designs can be implemented in many ways. Motorola provides a compatible family of host-computer and time-share programs upon which the user can develop his system software. However, where microprocessor systems are being developed for a variety of end uses and applications, the EXORciser with its resident software and hardware emulation capabilities may well prove to be the most efficient and least expensive system design and development tool.

Using the EXORciser in a typical design process normally begins by defining the functions to be performed by the proposed system. In this definition phase the designer makes the required trade-offs between the system hardware and software functions.

The designer now, using the appropriate memory and input/output modules, emulates his proposed system in the EXORciser. Recognizing that some systems may require special interface circuitry and customized circuitry, provisions have been made on the input/output modules for the designer to insert 14, 16 and 24 pin wirewrap sockets and construct the special interface circuitry. Also the designer can construct any customized circuitry on the Wirewrap Module.

The terminal, as illustrated, provides the means for communications between the designer and EXORciser. This can be done by means of the terminal keyboard, from paper tape, or from a cassette associated with the particular terminal in use.

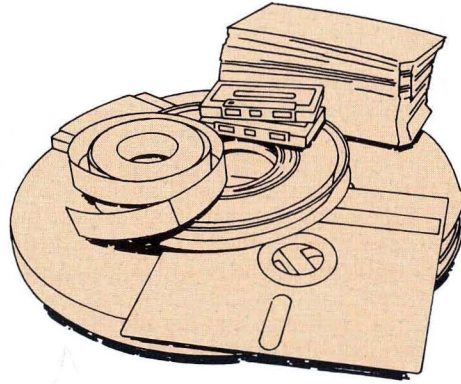

The M6800 resident software, when loaded into the EXORciser, provides the designer with a powerful tool on which to develop his software. Using the capabilities of the M6800 Resident Editor, the designer enters a source program either via the terminal keyboard or from the selected medium. The user now can modify and change his source program as required to meet his proposed systems requirements. This includes:

- Printing out all or any part of the program for detailed examination;
- Changing any characters or string of characters in the source program;
- Deleting or adding instruction lines or characters anywhere in the program.

At the end of the editing process, the Resident Editor will provide a source program that may be stored on paper tape, cassette, or diskette. This source program may be used in subsequent assembly operations on any of the compatible Motorola assemblers and cross assemblers.

The EXORciser's M6800 Co-Resident Assembler or the Resident Macro Assembler and Linking Loader can be used to automatically translate the source program into an object program. The Co-Resident Assembler requires a minimum of 8K bytes of memory while the Macro Assembler and Linking Loader requires a minimum of 14K bytes of memory.

*The resultant Object Program is available from the EXORciser in three forms.*

1. A printed assembly listing of the source program.
2. An Object Program on paper tape, cassette, or diskette.
3. A machine file, consisting of the machine-coded program stored directly into the EXORciser memory. This option permits the program to be executed immediately after assembly with no need for subsequent loading.

The Macro Assembler in its assembly process allows the assignment of the memory addresses of a program to be relocatable and assigned when loaded by the Linking Loader rather than fixed during the assembly operation. With the Co-Resident Assembler, the program address assignments are fixed and absolute in the assembly operation.

Once the designer has configured the EXORciser to emulate his hardware and has developed his programs, he is ready to debug his system. The EXORciser, with its EXbug system development Firmware, permits the user to debug both his system hardware and his system software as required until he has his system up and operating.

The EXORciser with its USE (User System Evaluator) option can be used to test and evaluate equipment external to its chassis. By removing the MC6800 Microprocessing Unit from the user's system and connecting the USE cable from the EXORciser into the MPU's socket, the EXORciser with its EXbug Firmware can be used to debug and troubleshoot microprocessor systems.

The EXORciser also can be used as a production tool. An EXORciser equipped with USE can be used in a final test area for testing the user's production system. With MOTEST, our component tester, the EXORciser also can be used to test the M6800 family of parts.

# EXORciser Bus Signals

The EXORciser bus interfaces the MPU Module with other modules being used in the EXORciser. This bus permits the EXORciser to be configured to meet a user's specific application.

**Data Bus (D0-D7)** – These eight bi-directional lines, when enabled, provide a two-way transfer of data between the MPU Module and the selected memory location. The data bus drivers on the modules are three-state logic devices.

**Address Bus (A0-A15)** – These 16 lines, when enabled, transfer the MPU memory address to the selected memory location. The MPU Module controls the operation of these lines through its three-state bus drivers.

**Read/Write (R/W)** – This MPU output signal indicates whether the MPU Module is performing a memory read (high) or write (low) operation. The normal standby state of this line is read (high). Also, when the MC6800 MPU on the module is halted, this signal will be in the read state.

**Valid Memory Address (VMA)** – This line, when high, indicates that the address on the bus is valid.

**Valid User's Address (VUA)** – This line, when high, indicates that the address on the address bus is valid and the EXORciser is not addressing its EXbug program.

**Memory Clock (MEMCLK)** – This is the basic clock signal used by the MPU Module to generate its  $\phi 1$  and  $\phi 2$  non-overlapping clock signals.

**Phase 1 ( $\phi 1$ ) Clock** – This signal is derived from the Memory Clock and is present during the MPU addressing time. This signal is controlled by the MPU Module.

**Phase 2 ( $\phi 2$ ) Clock** – This signal also is derived from the Memory Clock and used to synchronize the transfer of data on the data bus. This signal is controlled by the MPU Module.

**Bus Available (BA)** – The Bus Available signal will normally be a low level. When activated, it will go high indicating that the address bus is available. This will occur if the Halt line is low or the MC6800 MPU is in the WAIT state as the result of executing a WAI instruction. At such time, all the MPU Module three-state output drivers will go to their off state and other outputs to their normally inactive state. An interrupt command or actuating the ABORT or RESTART switch removes the MPU from the WAIT state.

**Interrupt Request (IRQ)** – This level sensitive input, on going low, requests that an interrupt sequence be generated in the MC6800 MPU. The MPU will wait until it completes the current instruction that it is executing before it recognizes this request. At that time, if the interrupt mask bit in the MPU Condition Code Register is not set, the MPU will begin the interrupt sequence.

**Non-Maskable Interrupt (NMI)** – This level sensitive input, on going low, requests that an interrupt sequence be generated within the MC6800 MPU. The MPU will wait until it completes the current instruction that it is executing before it recognizes this request. At that time, the MPU will begin its non-maskable interrupt routine.

**Reset** – This edge sensitive signal initiates an MC6800 MPU power-on vectored interrupt initialize routine when power is first applied to the EXORciser and each time the EXORciser's RESTART switch is actuated. This signal, in addition to resetting the module's MPU, is used to reset and initialize the rest of the EXORciser.

**Three-State Control (TSC)** – This input, when high, causes all of the MPU Module's Address Bus lines and R/W line to go to their off or high-impedance state. The Valid Memory Address and Valid User's Address signal will be forced low. The Data Bus is not affected by the Three-State Control. This signal is initially jumpered to ground on the MPU Module.

**Refresh Request (REFREQ)** – This signal, when low, initiates a memory refresh operation. The MPU Module, on receiving this input, stops generating the  $\phi 1$  and  $\phi 2$  clock signals with  $\phi 1$  high and, through the Refresh Grant command, instructs the initiating memory module to refresh itself.

**Refresh Grant (REFGRANT)** – The MPU Module, on receiving a Refresh Request input, generates a Refresh Grant signal to instruct the initiating module to refresh itself.

**Memory Ready (MEMRDY)** – This signal enables the MPU Module to work with slow memories. The MPU Module, on receiving a low level Memory Ready input, stops generating the  $\phi 1$  and  $\phi 2$  clock signals with  $\phi 2$  high. The initiating module, on completing its memory operation, returns the Memory Ready signal to a high level.

**Halt** – When this input is low, all activity in the MC6800 MPU will be halted. This input is level sensitive. In the MC6800 MPU will be halted. This input is level sensitive. In the halt mode, the machine will stop at the end of an instruction, Bus Available will be high, Valid Memory Address and Valid User's Address will be low, and all other three-state lines will be in their off or high-impedance state.

Transition of the Halt line must not occur during the last 250 ns of  $\phi 1$ . To insure single instruction operation, the Halt line must go high for one  $\phi 1$  clock pulse.

**Refresh Clock (REFCLK)** – This signal is generated by the dynamic memory module being used as the master refresh module. This signal is used to initiate a memory refresh operation on the dynamic modules functioning as slave refresh modules.

**Stand By (STDBY)** – This line is a low level during a power-fail condition and a high level during normal EXORciser operation.

## Bus Control

It is possible for a module other than the MPU Module to gain control of the bus. This module would place a low level Halt on the bus and monitor the Bus Available signal. When the MPU Module completes the instruction it is performing, it generates a high level Bus Available signal. The module requesting control of the bus now must pull the Three-State Control line low, forcing the MPU Module address bus drivers to their high-impedance state. The requesting module now has control of the EXORciser bus until it elects to relinquish control.

# MEX6800 MPU Module

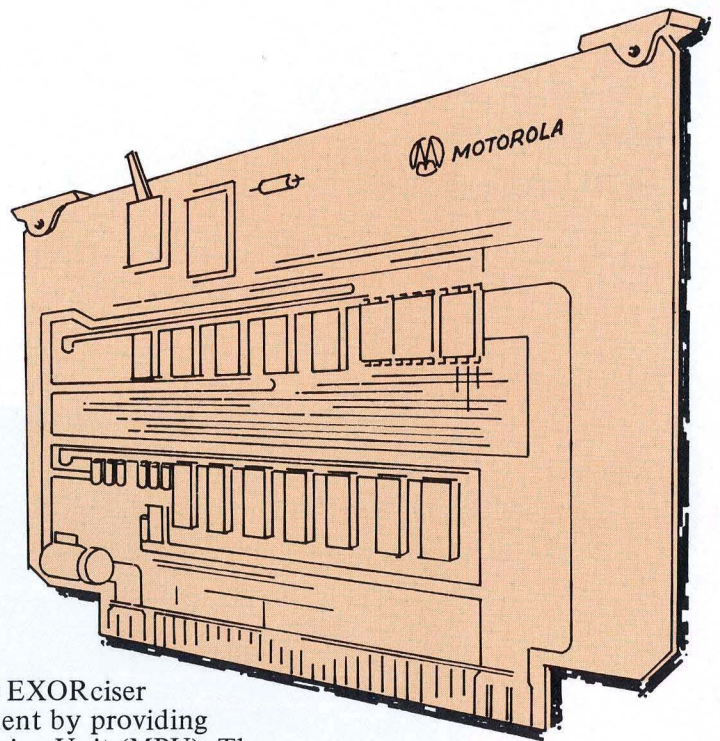

- Provides the MPU and clock functions for both the EXORciser Debug system and the emulated user's system
- Crystal controlled 1 MHz clock
- Provisions for an external clock
- Automatic system initialization and restart capability
- Dynamic memory refresh capability on a cycle stealing basis
- Capable of working with slow external memories

The MEX6800 MPU Module is the heart of both the EXORciser Debug system and the user's system under development by providing both the system clock and the MC6800 Microprocessing Unit (MPU). The MPU Module also automatically initiates an EXORciser restart operation when power is first applied to the EXORciser.

The clock circuit generates a crystal-controlled 1 MHz signal, but the system may be operated with an external clock at frequencies between 100 kHz and 1 MHz by means of a switch mounted on the MPU Module.

In addition to generating the basic EXORciser timing signals, the clock circuit provides the EXORciser with the capability of refreshing dynamic memories and working with slow memories. The dynamic memories are refreshed on a cycle stealing basis. In working with slow memories, the MPU Module stretches the clock pulse to give the memory sufficient time to complete its assigned operation.

## Specifications

(Note: Positive current flow is defined as flowing into the terminal, negative current flow as flowing from the terminal.)

Memory Size Capability	65,536 bytes maximum	Data Bus	Three-state TTL voltage compatible
Word Size	Data	8-bits	Input Logic "0"
	Address	16-bits	Input Logic "1"
Instruction Set	Instruction	8, 16, or 24 bits	Output Logic "0"
		72 variable length instructions	Output Logic "1"
Interrupts	Maskable and non-maskable real-time interrupts	Output Off-State Leakage Current	100 $\mu$ A at 2.6 V
Clock Signal	Software interrupt	Output Control Signals	TTL voltage compatible
	1 MHz; provision for external clock between 100 kHz and 1 MHz	Logic "0"	0.0-0.4 V
Input Control Signals	TTL Voltage Compatible	Logic "1"	2.4-5.25 V
	Logic "0"	0.0-0.8 V	Operating Temperature
Address Bus and R/W	Logic "1"	2.0-5.25 V	0 to 70°C
	Off-State Leakage Current	-40 $\mu$ A	Power Requirements
			5 Vdc at 700 mA
		Physical Dimensions:	9.75 x 5.75 x 0.062 in.
		W x H x T	

# MEX6800 MPU Module

**Resident**  
(also available as additional  
Optional Module)

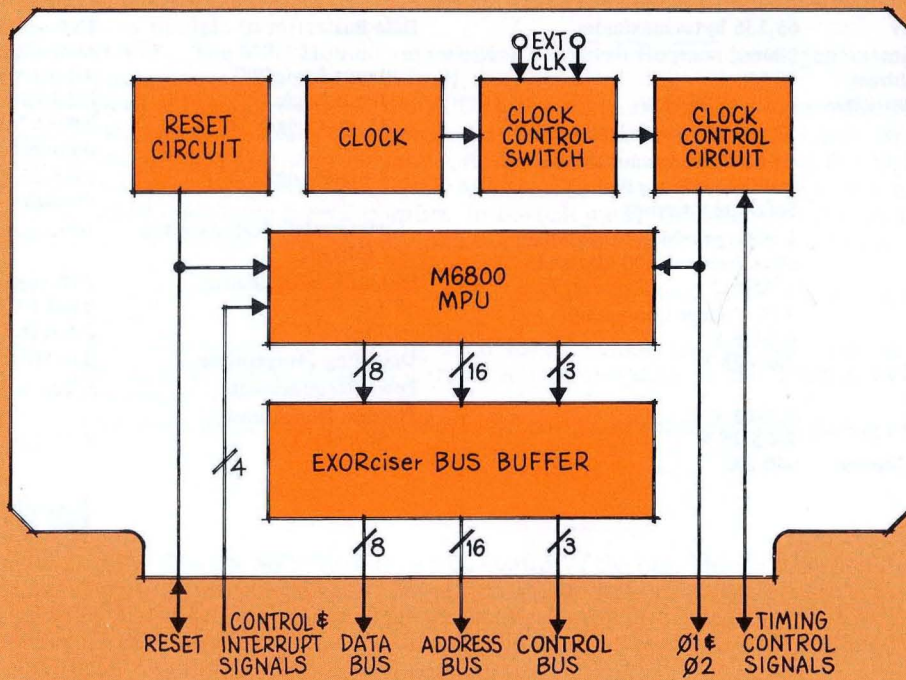
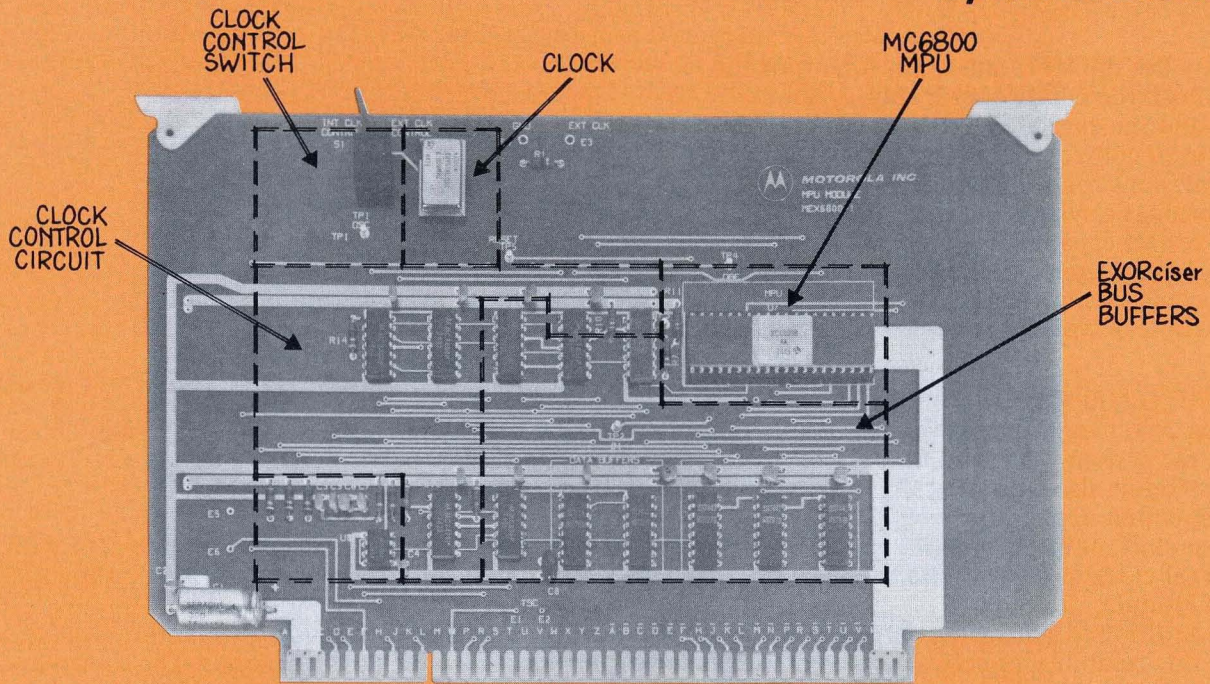

# Debug Module

- Provides EXbug system development Firmware
- Contains the special hardware to implement the EXbug functions
- Enables the user to communicate with the EXbug Firmware via a data terminal
- Interfaces EXORciser front panel switches and controls with the MPU

The Debug Module, through its EXbug Firmware and implementation hardware, provides the EXORciser with its unique capabilities to evaluate and debug a system under development. The EXbug Firmware is stored in the module's three MCM6830 ROMs with the module's two MCM6810 RAMs serving as a scratch pad memory for the EXbug routines.

Using the EXbug routines provides the designer virtually unlimited freedom in examining and debugging his proposed system hardware and software. He can, for example, search the input medium for a file, load a file into EXORciser memory, verify the contents in the EXORciser memory, print out the contents of the EXORciser memory, and record the memory contents on the selected medium. In between these input/output functions, the user can examine and, if required, change the memory contents. He can insert and remove one hardware breakpoint and up to eight software breakpoints. He also can run in real time or trace through the user's program or a selected portion of the user's program. While using these routines, the user modifies his hardware and software as required until he has his system up and running. The DISABLE switch on the module may be used to disable the EXbug routines.

The user communicates with EXbug via an external terminal working in conjunction with the Baud Rate Module and the Debug Module. The STOP-ON-ADDRESS/SYNC ENABLE switch on the Debug Module is used to generate a sync pulse at a pre-selected address or to enable the hardware breakpoint function.

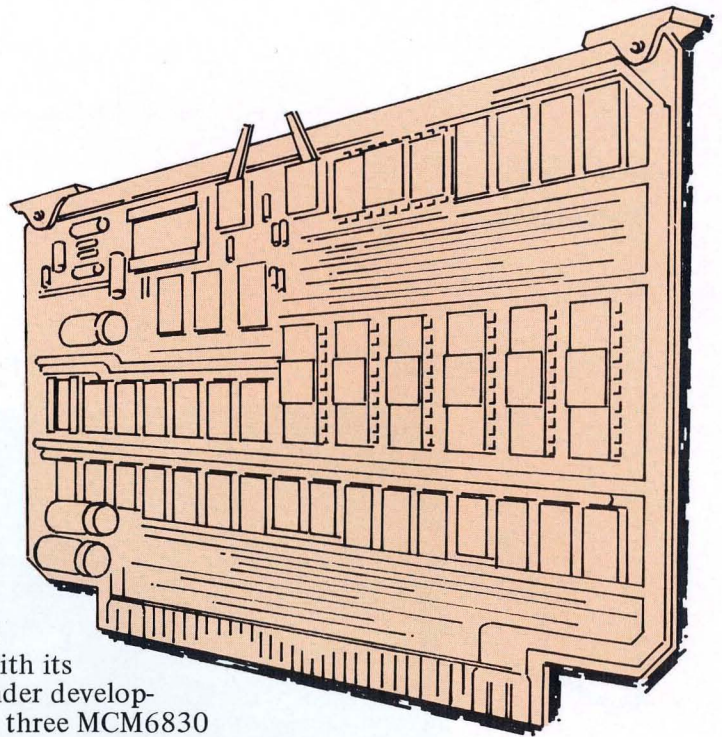

## Specifications

(Note: Positive current flow is defined as flowing into the terminal, negative current flow as flowing from the terminal.)

### Address and Control Bus

- Logic "0"
- Logic "1"

### Data Bus

- Input Logic "0"
- Input Logic "1"
- Output Logic "0"
- Output Logic "1"

### Operating Temperature

### Power Requirements

### Physical Dimensions

W x H x T

### TTL voltage compatible

- 0.0-0.85 V (-200  $\mu$ A max at 0.5 V)
- 2.0-5.25 V (25  $\mu$ A max at 5.25 V)

### Three-state TTL voltage compatible

- 0.0-0.85 V (-200  $\mu$ A max at 0.5 V)
- 2.0-5.25 V (25  $\mu$ A max at 5.25 V)
- 0.5 V max at 40 mA through a resistor to  $V_{CC}$
- 2.6 V min at -10 mA through a resistor to ground

0 to 70°C

- +5 Vdc at 1.3 A
- +12 Vdc at 500 mA
- 12 Vdc at 500 mA

9.75 x 5.75 x 0.062 in.

# Debug Module

# Resident

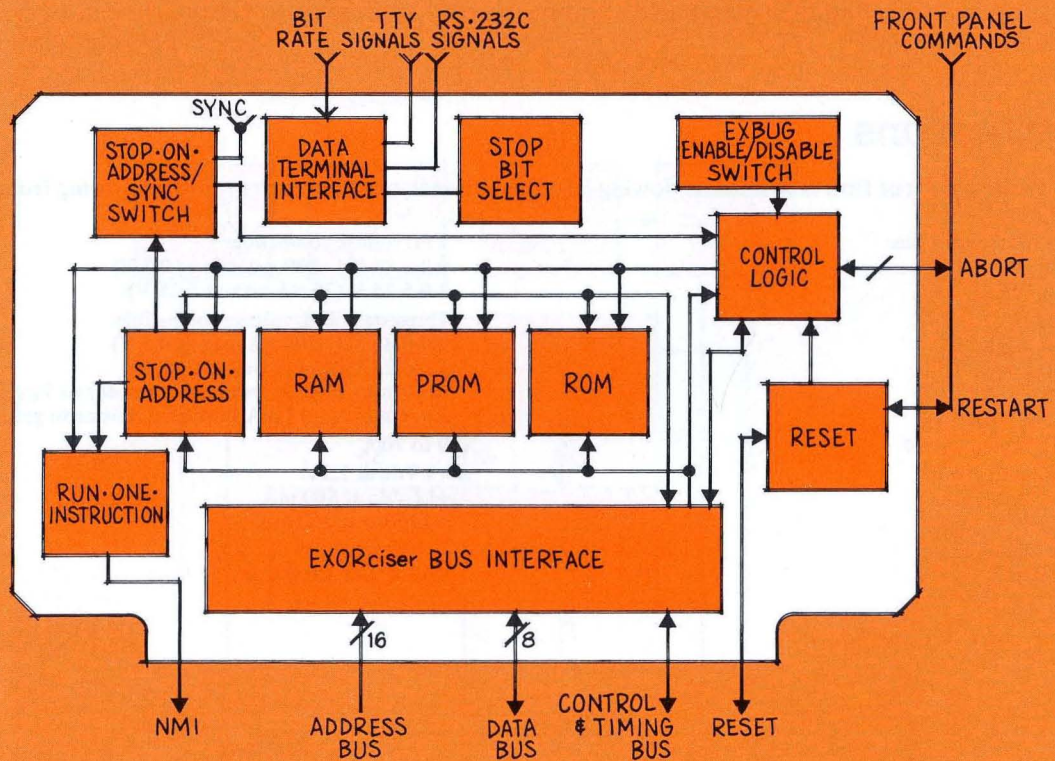
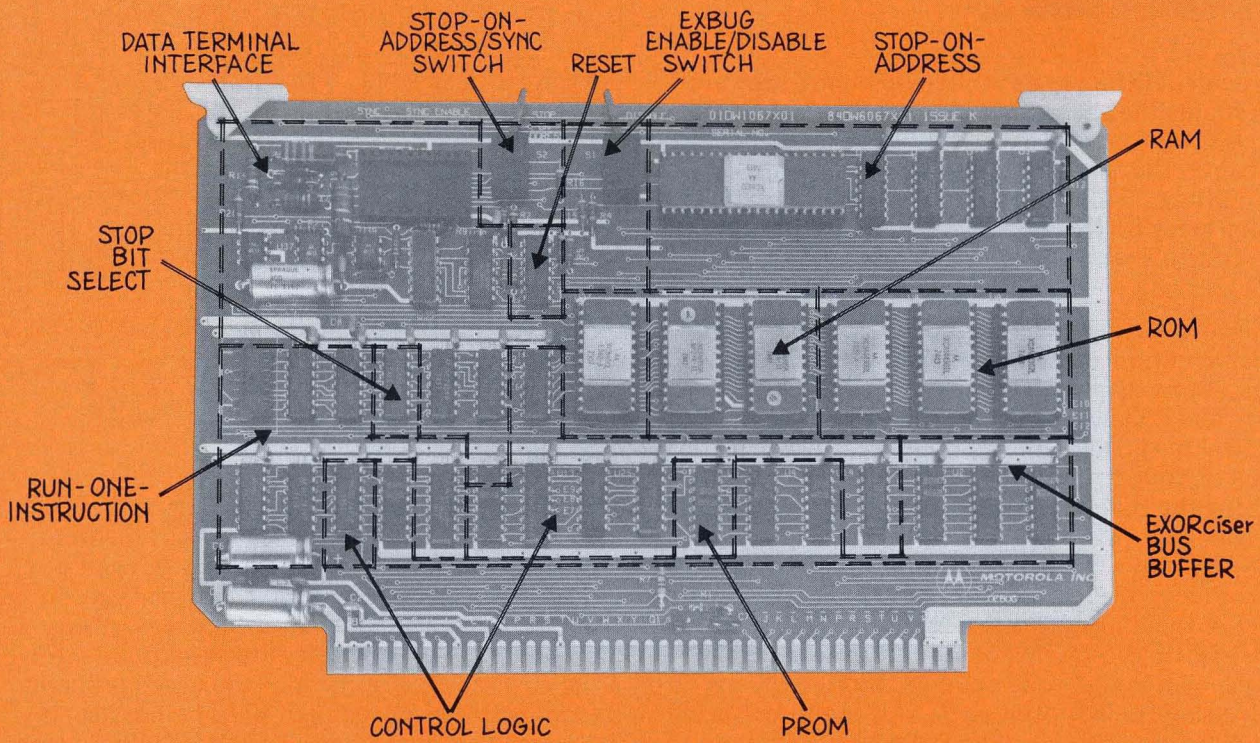

# Baud Rate Module

- Provides the EXORciser with eight switch-selectable baud rates between 110 and 9600.
- Provides an interface between the Debug Module and the selected data terminal
- Provides an interface between the front panel and the Debug Module

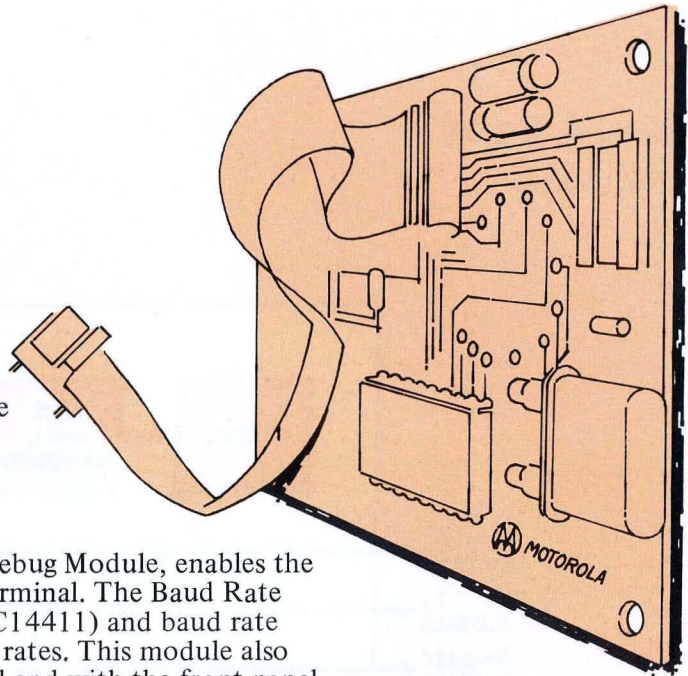

The Baud Rate Module, in conjunction with the Debug Module, enables the designer to communicate with EXbug via a data terminal. The Baud Rate Module's crystal oscillator baud rate generator (MC14411) and baud rate switch provide the EXORciser with eight standard rates. This module also interconnects the Debug Module to a data terminal and with the front panel. Included with the module is the front panel interconnect cable.

## Specifications

**Baud Rates:** 110,150,300,600,1200,  
(Switch Selectable) 2400,4800, and 9600

**Physical Dimensions:** 3.688 x 5.25 x 0.062 in.  
W x H x T

# Power Supply

- Provides all required EXORciser voltages
- Capable of supporting a full EXORciser rack of Modules

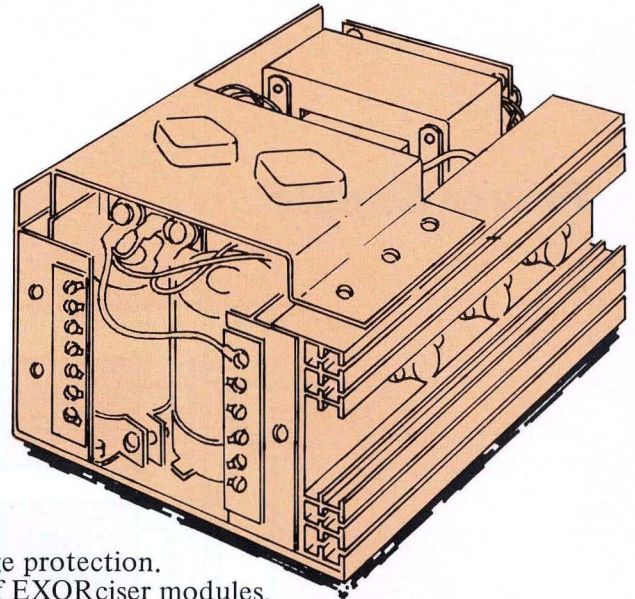

The power supply provides the EXORciser with +5 Vdc, +12 Vdc and -12 Vdc power sources. The +5 Vdc regulated source has both overload and overvoltage protection. This power source is capable of driving a complete rack of EXORciser modules.

The +12 Vdc and -12 Vdc sources are used to power portions of the interface circuitry between the EXORciser and a data terminal. These sources have overload protection and may be used to power custom circuitry on other modules.

## Specifications

**Output Voltages:** +5 Vdc @ 15 A  
-12 Vdc @ 1.5 A  
+12 Vdc @ 2.5 A

**Input Voltage:** 95-125/205-250 Vac

**Input Frequency:** 47 to 420 Hz, Single Phase

**Physical Dimensions:** 9.50 x 6.25 x 5.00 in.  
L x W x H

# Baud Rate Module

Resident

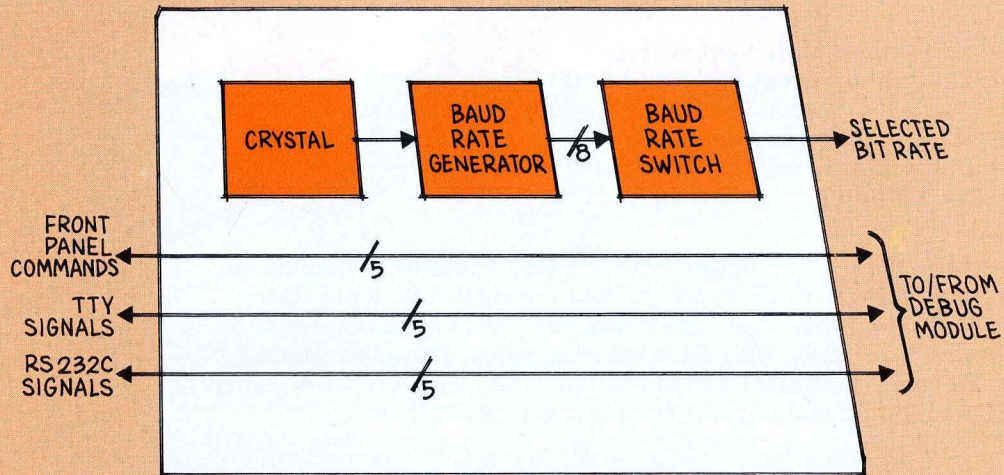

# Power Supply

Resident

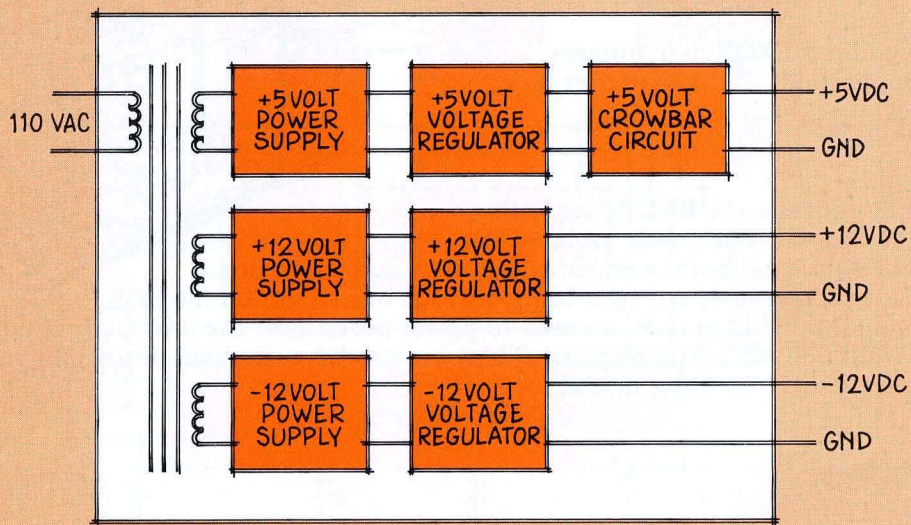

**MOTOROLA Semiconductor Products Inc.**

BOX 20912 • PHOENIX, ARIZONA 85036 • A SUBSIDIARY OF MOTOROLA INC.

# MEX6812-1 2K Static RAM Module

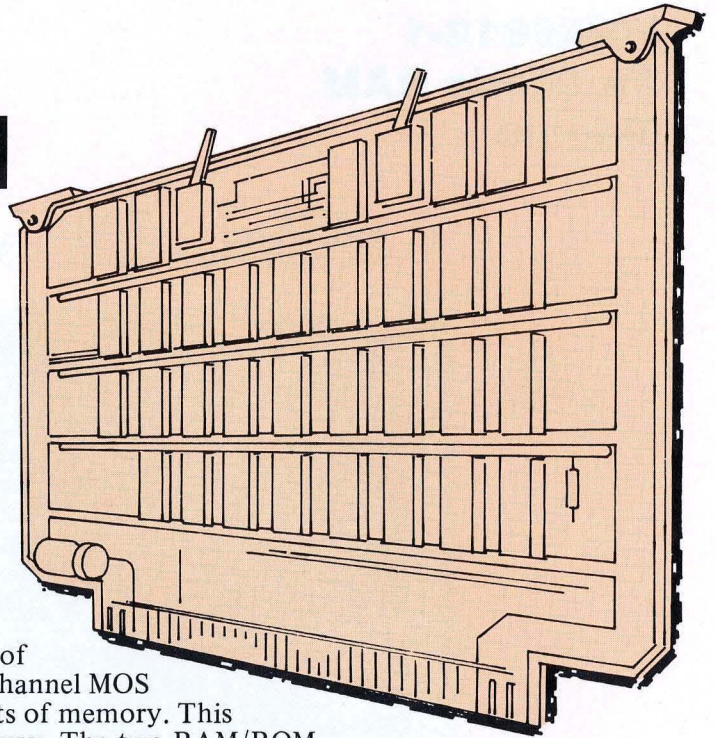

- 2048 x 8 bits of static N-channel MOS memory in 1K byte arrays
- Switch-selectable base memory address for each 1K RAM array
- Switch-selectable RAM/ROM (inhibited memory write function) capability for each array
- 500 nanosecond memory access time
- TTL voltage compatible
- Bus interface driver capability

The MEX6812-1 2K Static RAM Module, consisting of sixteen 2102-1 1024 x 1-bit RAMs or equivalent N-channel MOS memories, provides the EXORciser with 2048 x 8 bits of memory. This memory is organized into two separate 1024 byte arrays. The two RAM/ROM switches on the module determine whether their respective arrays are to simulate one (1024 x 8-bit) MCM6830 ROM or eight (128 x 8-bit) MCM6810 RAMs. Three-state bus buffers interface this module to the M6800 MPU over the EXORciser system bus.

The designer can select the base memory address, in 1024 bit increments, for each memory array by setting of the base memory address switches. Address decoders on this module monitor the 16 address lines and determine when the EXORciser's MPU is addressing their respective memory arrays. A logic circuit decodes three inputs, reads the RAM/ROM switches, and determines the memory function to be performed – read data from the memory, write data into the memory, or inhibit the memory write function.

## Specifications

(Note: Positive current flow is defined as flowing into the terminal, negative current flow as flowing from the terminal.)

Type Memory	MOS Static RAM
Memory Organization	2048 x 8 bits organized into two 1024 x 8 bit arrays
Memory Cycle Time	500 ns
Input Signals	TTL voltage compatible
Logic "0"	0.0-0.85 V (-200 $\mu$ A max at 0.4 V)
Logic "1"	2.0-5.25 V (25 $\mu$ A max at 5.25 V)
Data Bus	Three-state TTL voltage compatible
Input Logic "0"	0.0-0.85 V (-200 $\mu$ A max at 0.4 V)
Input Logic "1"	2.0-5.25 V (25 $\mu$ A max at 5.25 V)
Output Logic "0"	0.5 V max at 40 mA through a resistor to V <sub>CC</sub>
Output Logic "1"	2.6 V min at -10 mA through a resistor to ground
Output Off-State Leakage Current	100 $\mu$ A max at 2.6 V
Power Requirements	5 Vdc @ 1 A Max.
Physical Dimensions W x H x T	9.75 x 5.75 x 0.062 in.



# MEX6815-3

## 8K Dynamic RAM Module

- 8192 x 8 bits of dynamic NMOS memory in two 4096 byte arrays
- Switch selectable base memory address for each memory array
- Each array switch selectable as RAM or ROM (RAM protected by inhibiting memory write function)
- Fully decoded or partial decoded module address selection
- Cycle stealing memory refresh operation
- TTL voltage compatible
- Bus driver capability
- Operates up to 1.5 MHz system clock

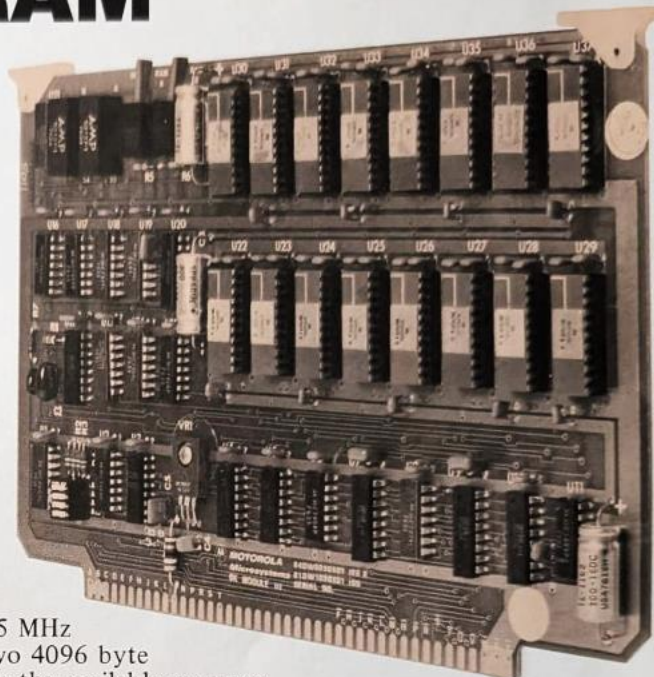

The MEX6815-3 8K Dynamic RAM Module consists of sixteen MCM6605, or equivalent, N-Channel MOS memory devices that provide the EXORciser with 8192 x 8 bits of memory which will operate up to 1.5 MHz system clock. This memory module is divided into two 4096 byte memory arrays which may be located anywhere within the available memory map by means of two base memory address switches (0000, 4096, 8192, etc.). For added flexibility, this module has an address line select switch for full or partial decoding of address lines and two ROM/RAM switches that inhibit the memory write capability thereby causing the RAM memory to look like ROM memory.

This module interfaces to the M6800 MPU over the EXORciser system bus via three-state bus buffers. Control logic initiates a memory refresh operation once every 32  $\mu$ s; the module refreshes its memory on a cycle stealing basis.

### Specifications

(Note: Positive current flow is defined as flowing into the terminal, negative current flow as flowing from the terminal.)

Memory Type	N-Channel MOS Dynamic RAM
Memory Organization	8192 x 8 bits organized into two 4096 x 8-bit arrays
Cycle Time	750 ns
Read Access Time	350 ns from memory clock
Input Signals	
Control Bus	
Logic "0"	0.0-0.8 V (-200 $\mu$ A max at 0.5 V)
Logic "1"	2.0-5.25 V (25 $\mu$ A max at 5.25 V)
Address Bus	
Logic "0"	0.0-0.8 V (-500 $\mu$ A max at 0.5 V)
Logic "1"	2.0-5.5 V (80 $\mu$ A max at 5.5 V)
Data Bus	
Input Logic "0"	0.0-0.8 V (200 $\mu$ A max at 0.5 V)
Input Logic "1"	2.0-5.25 V (25 $\mu$ A max at 5.25 V)
Output Logic "0"	0.5 V max at 40 mA through a resistor to $V_{CC}$
Output Logic "1"	2.6 V min at -10 mA through a resistor to ground
Operating Temperature	0 <sup>o</sup> to 70 <sup>o</sup> C
Power Requirements	+5 V at 600 mA +12 V at 250 mA -12 V at 50 mA
Physical Dimensions	
W x H x T	9.75 x 5.75 x 0.062 in.

EXORciser is a trademark of Motorola Inc.

# MEX6815-3 8K Dynamic RAM Module

Option

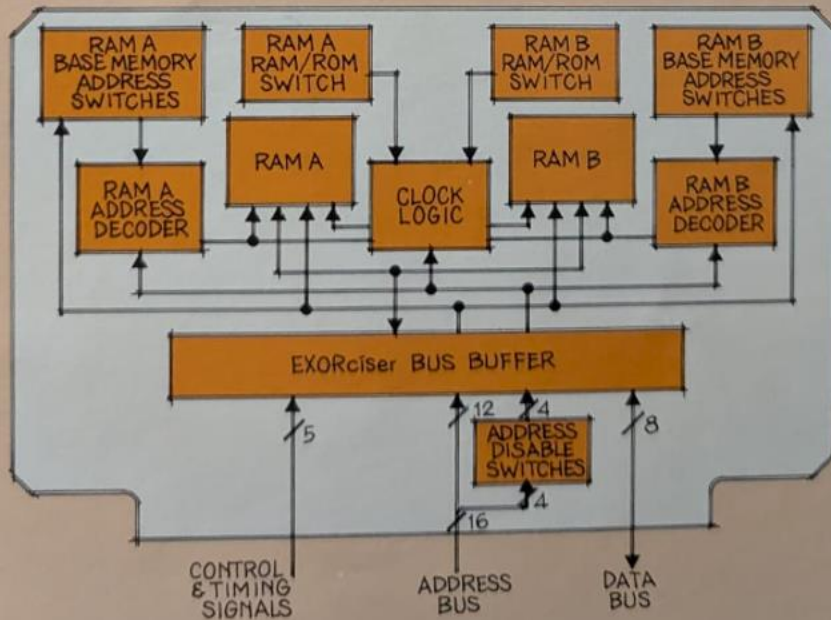
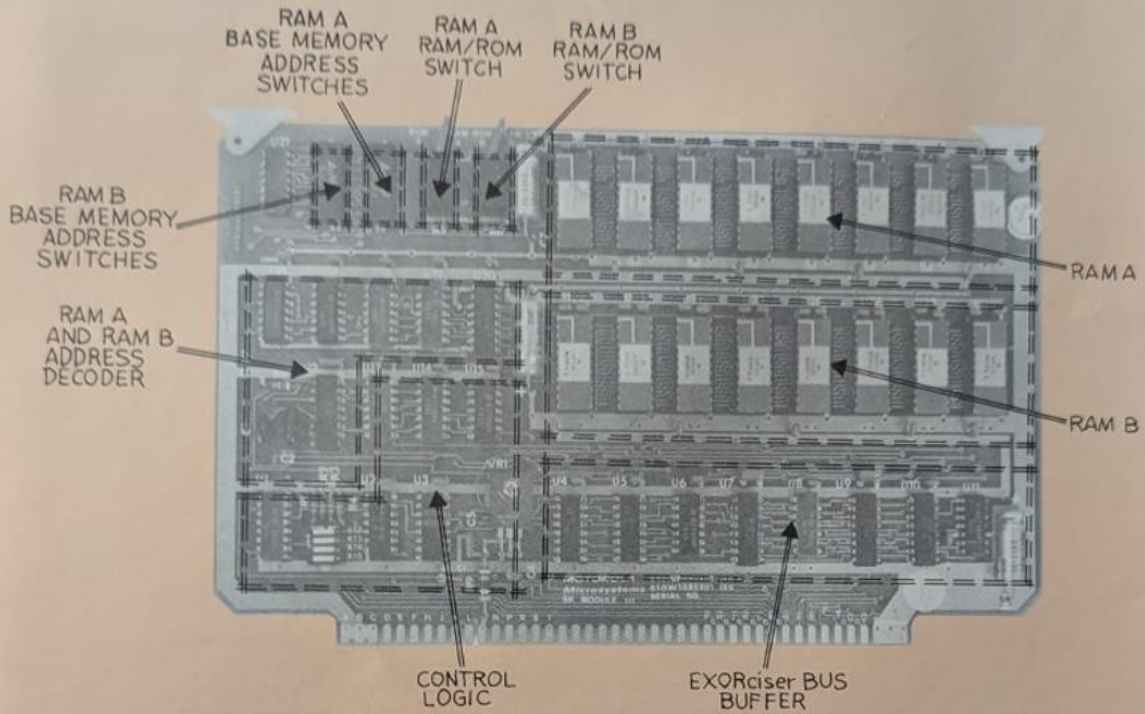

**MOTOROLA Semiconductor Products Inc.**

BOX 20912 • PHOENIX, ARIZONA 85036 • A SUBSIDIARY OF MOTOROLA INC.

HELL 4 PRINTED IN USA 1-77 SPECIAL LINE MARK



# MEX6816-1

## 16K Dynamic RAM Module

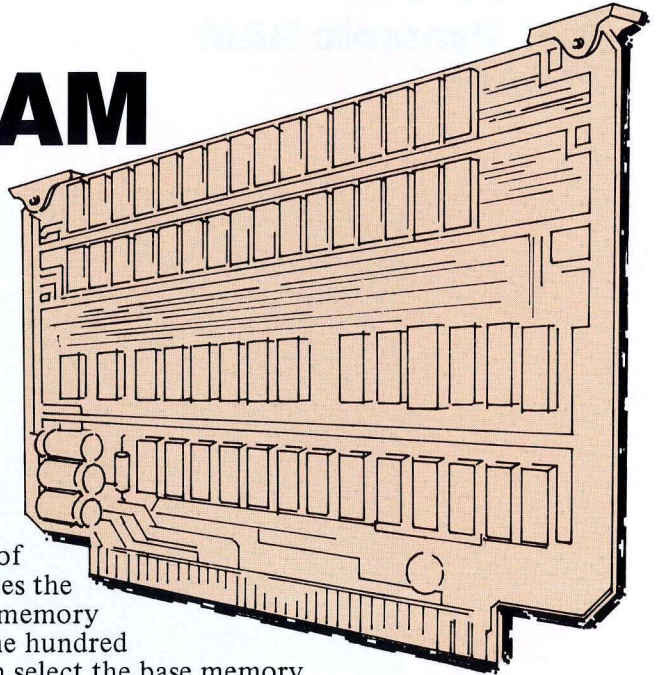

- 16,384 x 8 bits of dynamic NMOS memory in one array
- Switch selectable base memory address for the memory array
- Cycle stealing memory refresh operation
- Optional even parity capability (consult factory)
- TTL voltage compatible
- Bus drive capability

The MEX6816-1 16K Dynamic RAM Module, consisting of 16 MCM6604L2 N-Channel MOS memory devices, provides the EXORciser with 16,384 bytes of dynamic memory. This memory is organized into one 16K memory array and simulates one hundred twenty-eight 128 x 8 bit MCM6810A RAMs. The user can select the base memory address for this array through setting the base memory address switches.

The address multiplexer in a refresh operation selects the memory location to be refreshed. During normal operation this circuit transfers its six address inputs to the EXORciser bus buffer. The EXORciser bus buffer latches its address input. The address decoder determines when the MPU is addressing its memory array and enables the control logic circuits. The control logic now decodes its control and timing inputs and determines the module's operation. Working with the EXORciser bus buffer, it controls the address multiplexing required by the MCM6604L2 devices. The control logic also decodes the Read/Write command and determines whether the module is to perform a memory read or memory write operation.

The control logic initiates a memory refresh operation once every 32  $\mu$ s and the module refreshes its memory on a cycle stealing basis.

The optional parity circuit generates a parity bit during a memory write operation and checks that data during a memory read operation. On detecting a parity error, the circuit generates the PARITY ERROR and PARITY ERROR flag signals. Consult the factory for details on this option.

### Specifications

(Note: Positive current flow is defined as flowing into the terminal, negative current flow as flowing from the terminal.)

Memory Type	N-channel MOS dynamic RAM (MCM6604L2 devices)
Memory Organization	8,192 x 8 bits, 12,888 x 8 bits, or 16,384 x 8 bits organized into one array
Parity	Optional even parity – consult factory
Read Access Time	350 ns from row address strobe (approximately 300 ns from memory clock)
Input Signals	TTL voltage compatible
Control Lines	
Logic "0"	0.0-0.85 V (-200 $\mu$ A max at 0.4V)
Logic "1"	2.0-5.25 V (25 $\mu$ A max at 5.25 V)
Address	
Logic "0"	0.0-0.8 V (-2.0 mA max at 0.5 V)
Logic "1"	2.0-5.25 V (1.0 mA max at 5.5 V)
Data Bus	
Input Logic "0"	0.0-0.85 V (-200 $\mu$ A max at 0.4 V)
Input Logic "1"	2.0-5.25 V (25 $\mu$ A max at 5.25 V)
Output Logic "0"	0.5 V max at -40 mA through a resistor to $V_{CC}$
Output Logic "1"	2.6 V min at -10 mA through a resistor to ground
Operating Temperature	0 to 70° C
Power Requirements	+5 Vdc at 1.5 A max +12 Vdc at 1.6 A max -12 Vdc at 110 mA max
Physical Dimensions	
W x H x T	9.75 x 5.75 x 0.062 in.

**MEX6816-1**  
**16K Dynamic RAM**  
**Module**

**Option**

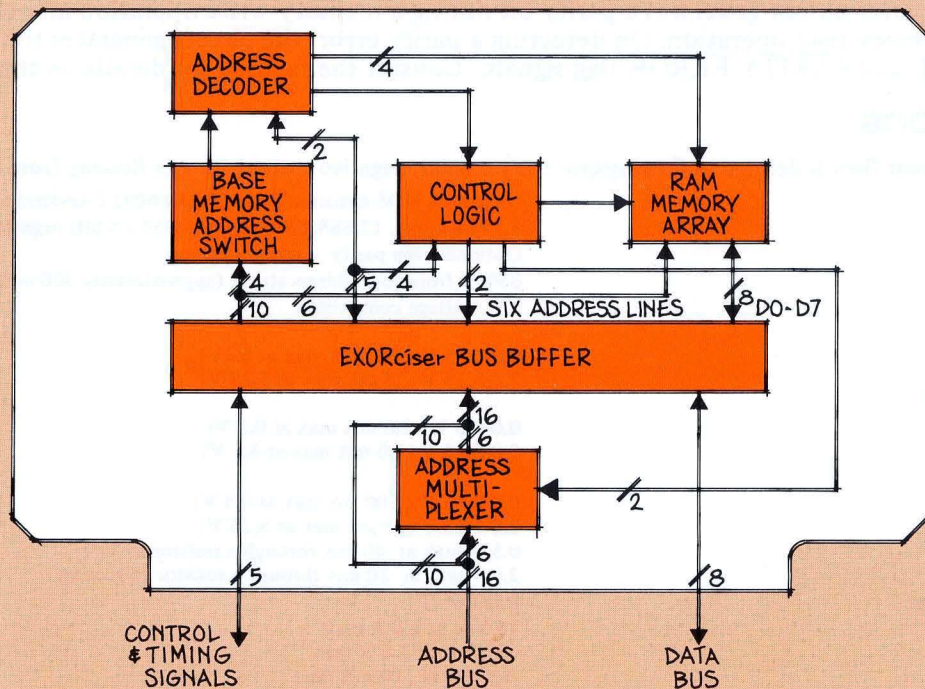
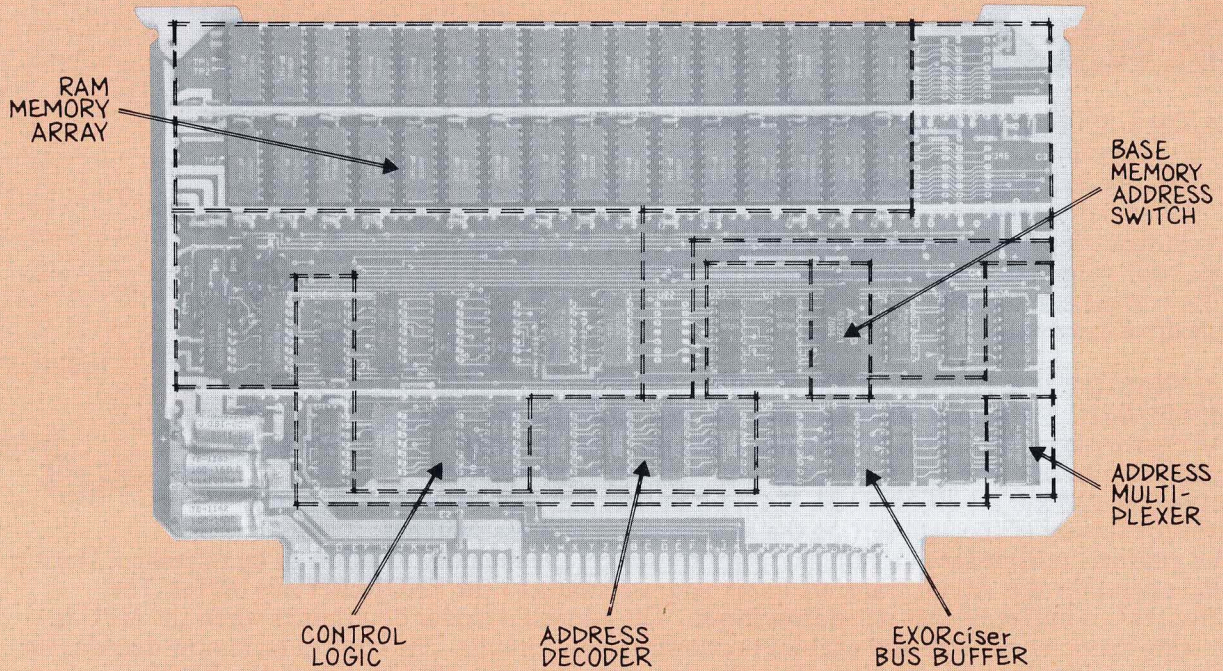

**MOTOROLA Semiconductor Products Inc.**

BOX 20912 • PHOENIX, ARIZONA 85036 • A SUBSIDIARY OF MOTOROLA INC.

10211 PRINTED IN USA 5-76 IMPERIAL LITHO 857297

20K

# MEX6820

## Input/Output Module

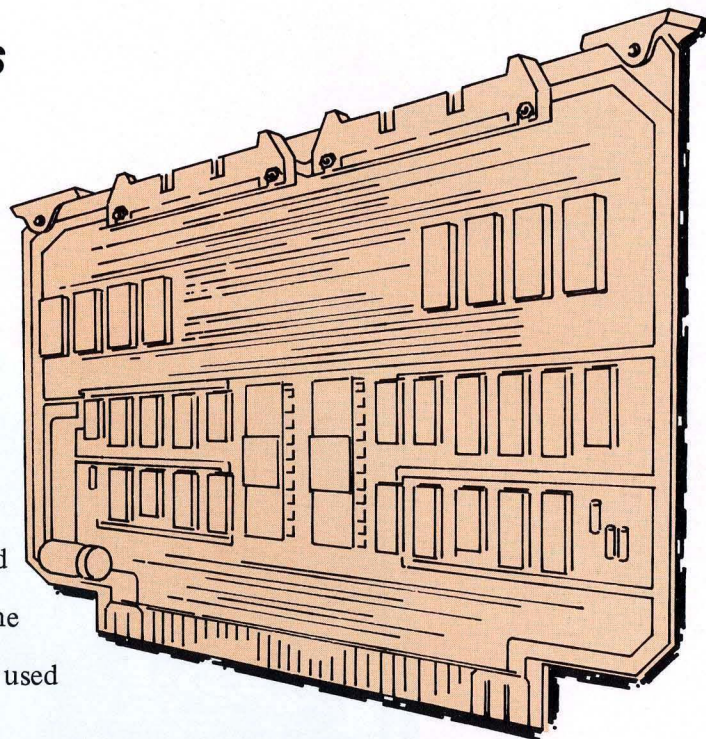

- Four 8-bit input/output ports for peripheral interfacing
- Eight individually controlled interrupt lines – four of which may be used as peripheral control lines
- Program controlled maskable interrupt capability
- Each MC6820 Peripheral Interface Adapter addressed as memory
- Switch selectable base memory address for each of the two MC6820 Peripheral Interface Adapter devices
- Provisions on the module for wirewrap sockets to be used in constructing custom interface circuitry

The MEX6820 Input/Output Module, containing two MC6820 Peripheral Interface Adapters (PIA's), provides a flexible means of interfacing the EXORciser with a user's defined process or peripheral device. This module, in effect, connects the two PIA's between the MPU and the peripheral device(s). The designer has the option of interfacing a peripheral directly to the PIA's TTL voltage compatible I/O ports and control lines, or through custom interface circuitry. (The peripheral interface lines of the PIA are PA0-PA7, PB0-PB7, CA1, CA2, CB1, and CB2.) The I/O Module has provisions for standard 14, 16, and 24 pin wirewrap sockets, thus permitting the construction of custom interfacing circuits on the module.

The EXORciser's MC6800 MPU addresses each of the PIA's as four locations in memory. Address switches allow the user to select base memory locations for each PIA. Altering the settings of the address enable/disable switches sets up the Input/Output Module to emulate a design that may or may not use all 16 address lines. Address decoders determine when the MPU is addressing a particular PIA's register and also signal the control logic to decode its inputs. The control logic, by decoding the MPU timing and control signals, manages the data flow through the I/O Module's buffers. These three-state buffers interface the I/O Module to the MC6800 MPU over the EXORciser bus.

MEX68IC I/O Interconnection Cables are used to connect an Input/Output Module to a peripheral. One end of this flatribbon cable is terminated with a 50-pin flatribbon connector; the other end is not terminated. Two MEX68IC cables should be ordered with each MEX6820 Input/Output Module.

## Specifications

(Note: Positive current flow is defined as flowing into the terminal, negative current flow as flowing from the terminal.)

<b>Input Signals</b>	<b>TTL voltage compatible</b>
Logic "0"	0.0-0.85 V (-200 $\mu$ A max at 0.4 V)
Logic "1"	2.0-5.25 V (25 $\mu$ A max at 5.25 V)
<b>Data Bus</b>	<b>Three-state TTL voltage compatible</b>
Input Logic "0"	0.0-0.85 V (-200 $\mu$ A max at 0.4 V)
Input Logic "1"	2.0-5.25 V (25 $\mu$ A max at 5.25 V)
Output Logic "0"	0.5 V max at 40 mA through a resistor to V <sub>CC</sub>
Output Logic "1"	2.6 V min at -10 mA through a resistor to ground
Output Off-State Leakage Current	100 $\mu$ A max at 2.6 V
<b>MC6820 Peripheral Interface Adapter Signals*</b>	<b>TTL voltage compatible</b>
PA0-PA7 Input/Output Lines	Three-state TTL voltage compatible
PB0-PB7 Input/Output Lines	TTL voltage compatible
CA1, CA2, and CB1 Control Signals	Three-state TTL voltage compatible
CB2 Control Signal	TTL voltage compatible
IRQA and IRQB Signals	0 to 70°C
<b>Operating Temperature</b>	5 Vdc at 2 A max
<b>Power Requirements</b>	9.75 x 5.75 x 0.062 in.
<b>Physical Dimensions</b>	
W x H x T	

\*See MC6820 data sheet for specifications on these signals.

# MEX6820 Input/Output Module

Option

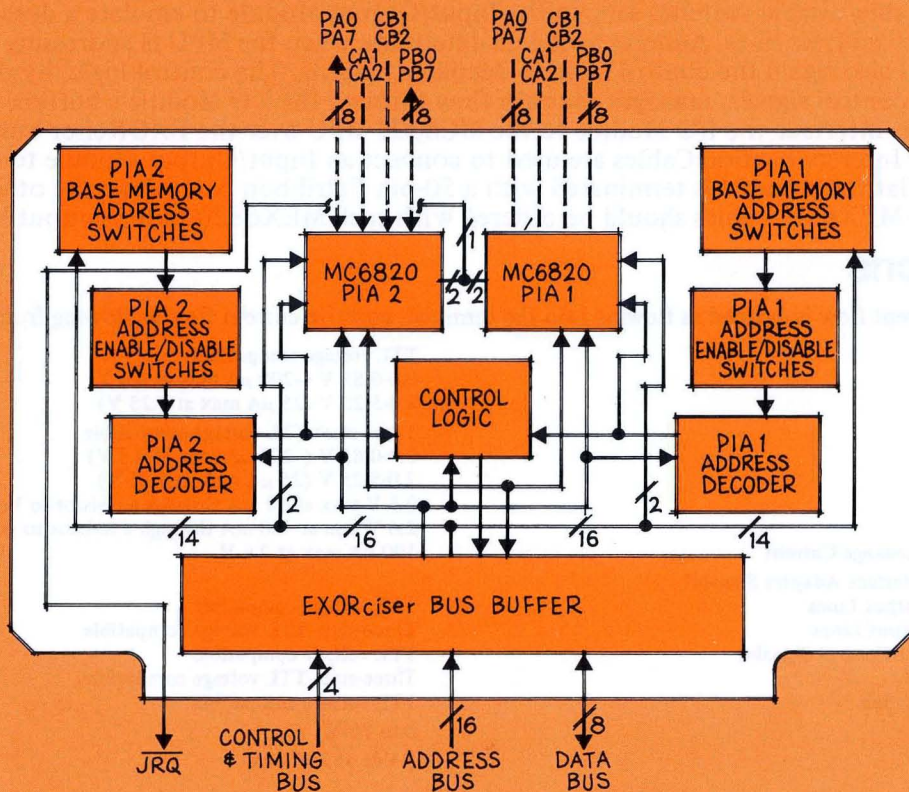
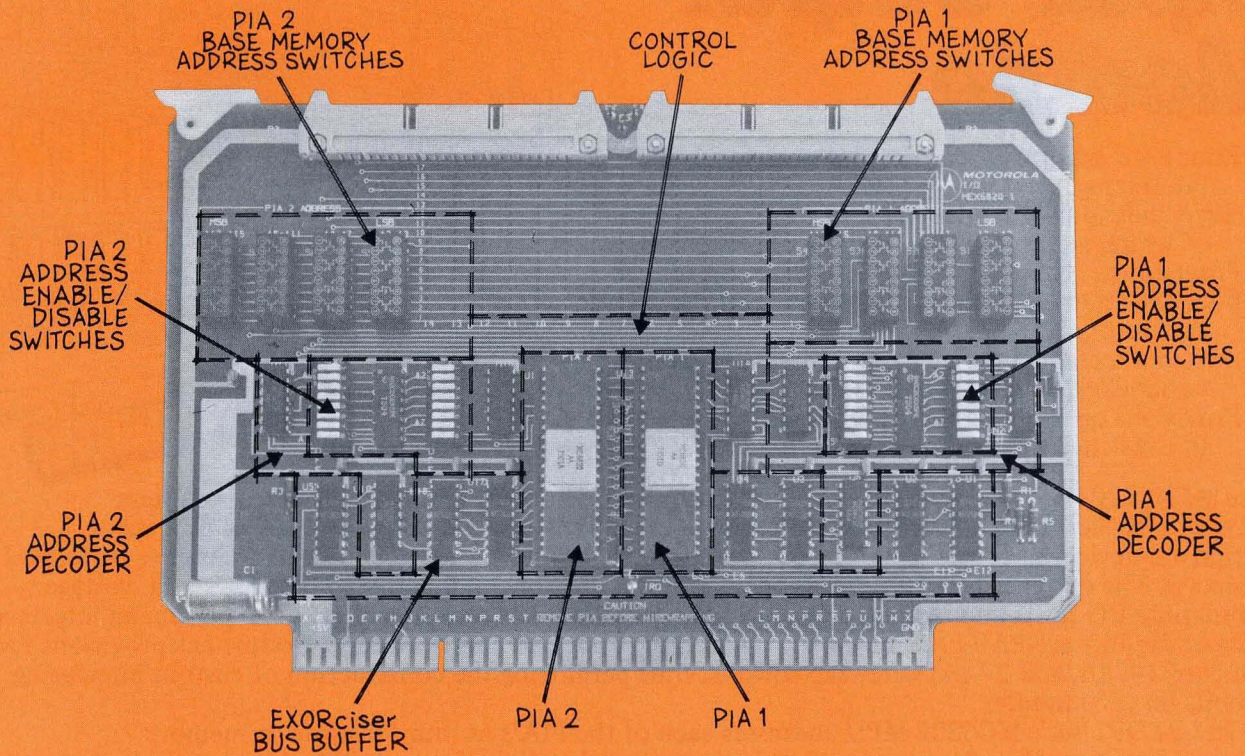

**MOTOROLA Semiconductor Products Inc.**

BOX 20912 • PHOENIX, ARIZONA 85036 • A SUBSIDIARY OF MOTOROLA INC.



**MOTOROLA**

# MEX6850 ACIA Module

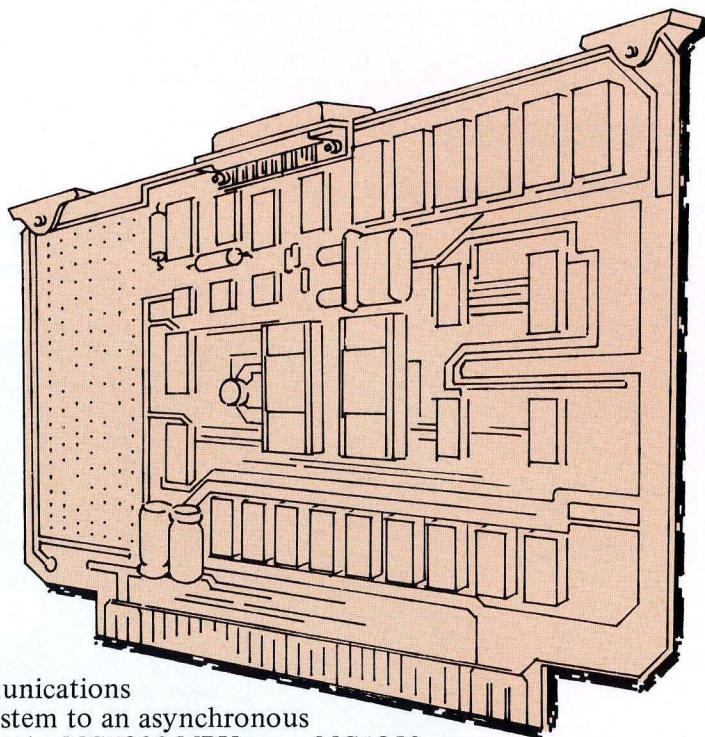

- Eight or nine-bit transmission
- Program-selectable odd, even, or no parity
- TTY and RS-232C data terminal interface capability
- Program-selectable divide-by 16 and 64 clock modes
- Program-selectable one or two stop bits
- Eight switch-selectable baud rates between 110 and 9600 baud

The MEX6850 ACIA Module (Asynchronous Communications Interface Adapter) interfaces the EXORciser base system to an asynchronous data communications device. This module appears to the MC6800 MPU as an MC6850 ACIA. In preparing a program for this module, the designer determines parity, the number of stop bits and the ACIA's clock mode. The user can select one or two stop bits; odd, even, or no parity; the clock mode; and the number of data bits to be transferred.

The user, in setting up this module, selects one of the eight standard switch selectable baud rates between 110 and 9600. He has the option of interfacing directly with a TTY (20 mA neutral current loop), and an RS-232C compatible terminal, or of constructing a custom interface circuit for some other peripheral. The module can be configured to appear as a data terminal or modem to an external communications device. It has provisions for standard 14, 16, and 24 pin wirewrap sockets to allow for the construction of customized circuits.

The EXORciser's MPU addresses the ACIA as if it were two locations in memory. By proper setting of the base memory address switches, the user can select the base memory address for the ACIA. The address enable/disable switches activate or de-activate individual address lines. This allows the EXORciser to emulate systems not using all 16 address lines. The address decoder determines when the MPU is addressing its ACIA and enables the control logic to decode its inputs. The control logic, by decoding of the MPU timing and control signals, controls the flow of data through the EXORciser bus buffer. The EXORciser bus buffer interfaces the ACIA Module with the EXORciser bus.

## Specifications

(Note: Positive current flow is defined as flowing into the terminal, negative current flow as flowing from the terminal.)

### Address and Control Bus

Logic "0"

Logic "1"

### Data Bus

Input Logic "0"

Input Logic "1"

Output Logic "0"

Output Logic "1"

Output Off-State Leakage Current

### Switch selectable baud rates

### Signal Characteristics

### TTY Reader Control Signal

### RS-232 Interface Signals

### Power Requirements

### Physical Dimensions

W x H x T

### TTL voltage compatible

0.0-0.85 V (-200  $\mu$ A max at 0.4 V)

2.0-5.25 V (25  $\mu$ A max at 5.25 V)

### Three-state TTL voltage compatible

0.0-0.85 V (-200  $\mu$ A max at 0.4 V)

2.0-5.25 V (25  $\mu$ A max at 5.25 V)

0.5 V max at 40 mA through a resistor to  $V_{CC}$

2.6 V min at -10 mA through a resistor to ground

100  $\mu$ A max at 2.6 V

110, 150, 300, 600, 1200, 2400, 4800, and 9600

TTY (20 mA neutral current loop) or EIA RS-232C compatible

Control signal for TTY devices modified for external control

RS-232C signals to interface with an RS-232C data terminal.

Can be modified to interface with any RS-232C modem.

+5 Vdc @ 750  $\mu$ A

+12 Vdc @ 500  $\mu$ A

-12 Vdc @ 500  $\mu$ A

9.75 x 5.75 x 0.062 in.

# MEX6850 ACIA Module

Option

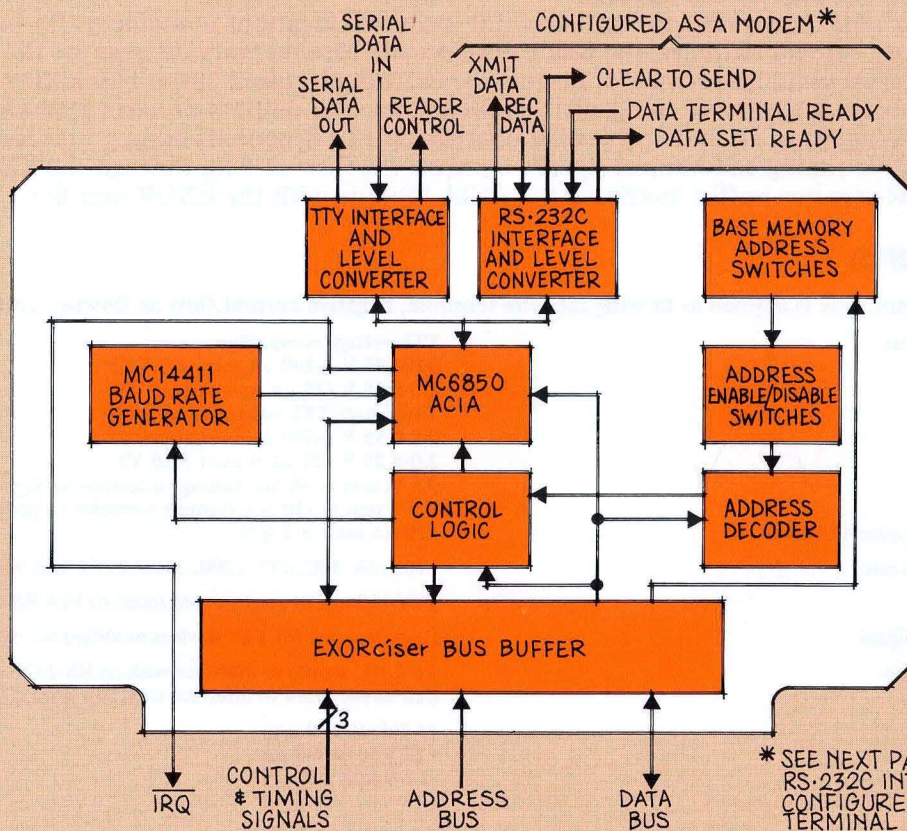
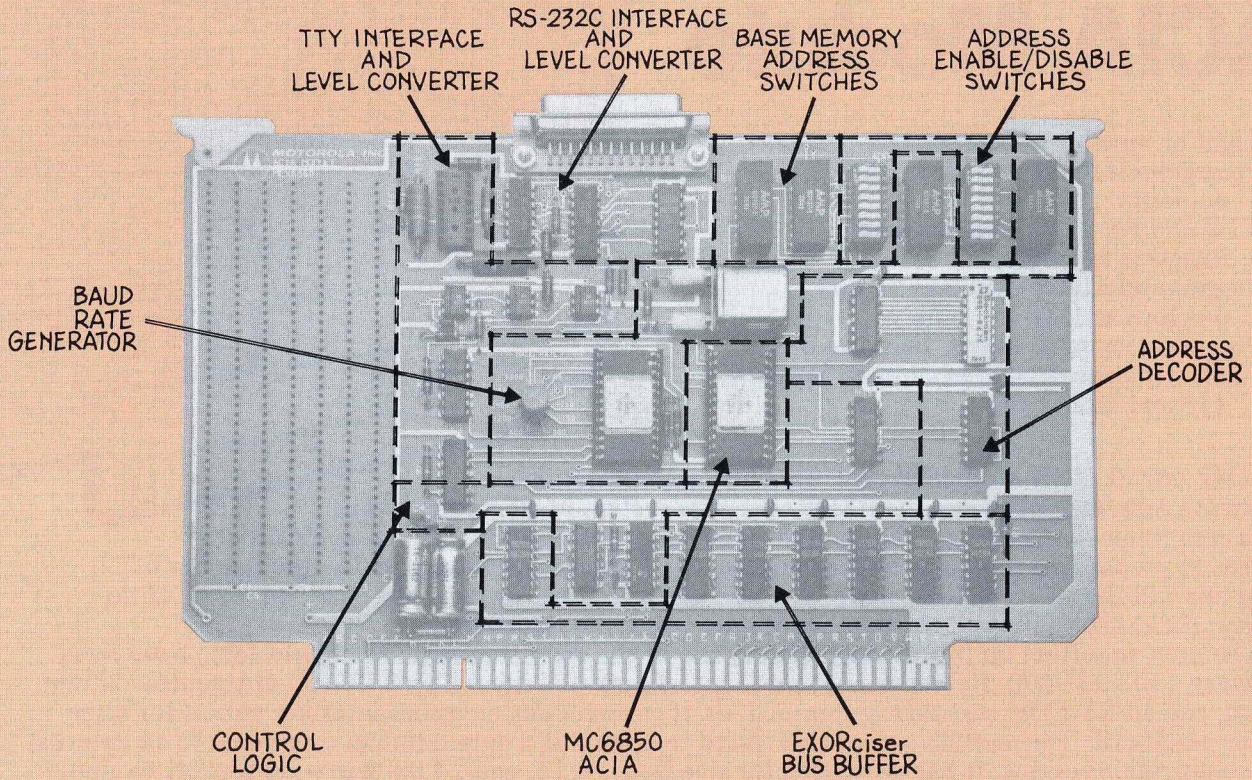

\* SEE NEXT PAGE FOR RS-232C INTERFACE CONFIGURED AS A TERMINAL

# Terminal Interface Lines

The user has the option of interfacing the MEX6850 ACIA Module with a TTY (20 mA neutral current loop), an RS-232C compatible terminal, or of constructing a custom interface circuit. In interfacing an RS-232C communications device with the module, the user also has the option of configuring the module to appear as a terminal or as a modem.

## TTY Interface Signals

**Serial Data In** – This line accepts the input from a TTY terminal.

**Serial Data Out** – This line transfers data to a TTY terminal.

**Serial Data Common** – This line provides a return for the Serial Data In and Serial Data Out signals.

**Reader Control** – This signal provides the control required to operate the paper tape reader on a modified manual TTY data terminal.

**Reader Common** – This line is connected to EXORciser ground and provides a return for the Reader Control signal.

## RS-232C Interface Signals

**Transmit Data** – This line transfers data from a terminal to a modem.

**Receive Data** – This line transfers data from a modem to a terminal.

**Clear to Send** – This signal, when high, indicates that the modem is ready to transmit data.

**Request to Send** – This signal prepares the modem for data transfer. When high, this signal places the modem in the transmit mode; when low, in the receive mode.

**Data Terminal Ready** – This line, when high, indicates to the modem that the terminal connected into the system is ready to receive or transmit data.

**Data Set Ready** – This signal is a high level when the modem is connected to the terminal and indicates to the terminal that the modem is ready.

**Received Line Signal Detector** – This signal, also called carrier detect, is a high level when the modem is receiving a signal meeting its criteria.

**Power Ground** – Common for the 12 volt source. This line provides a safety ground connection between the RS-232C compatible communications device and the EXORciser.

**Signal Ground** – This line provides a common signal connection to the RS-232C communications device.

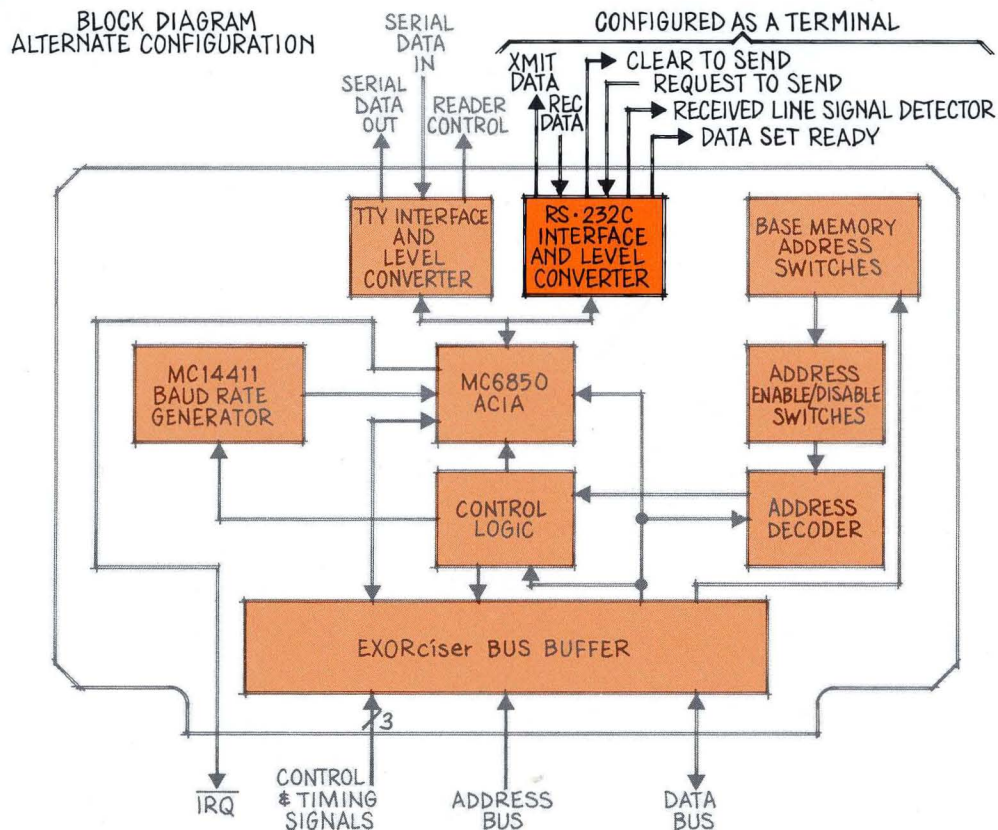



**MOTOROLA Semiconductor Products Inc.**

BOX 20912 • PHOENIX, ARIZONA 85036 • A SUBSIDIARY OF MOTOROLA INC.

10211 PRINTED IN USA 5-76 IMPERIAL L1740 857297 20H

 **MOTOROLA MICROSYSTEMS**

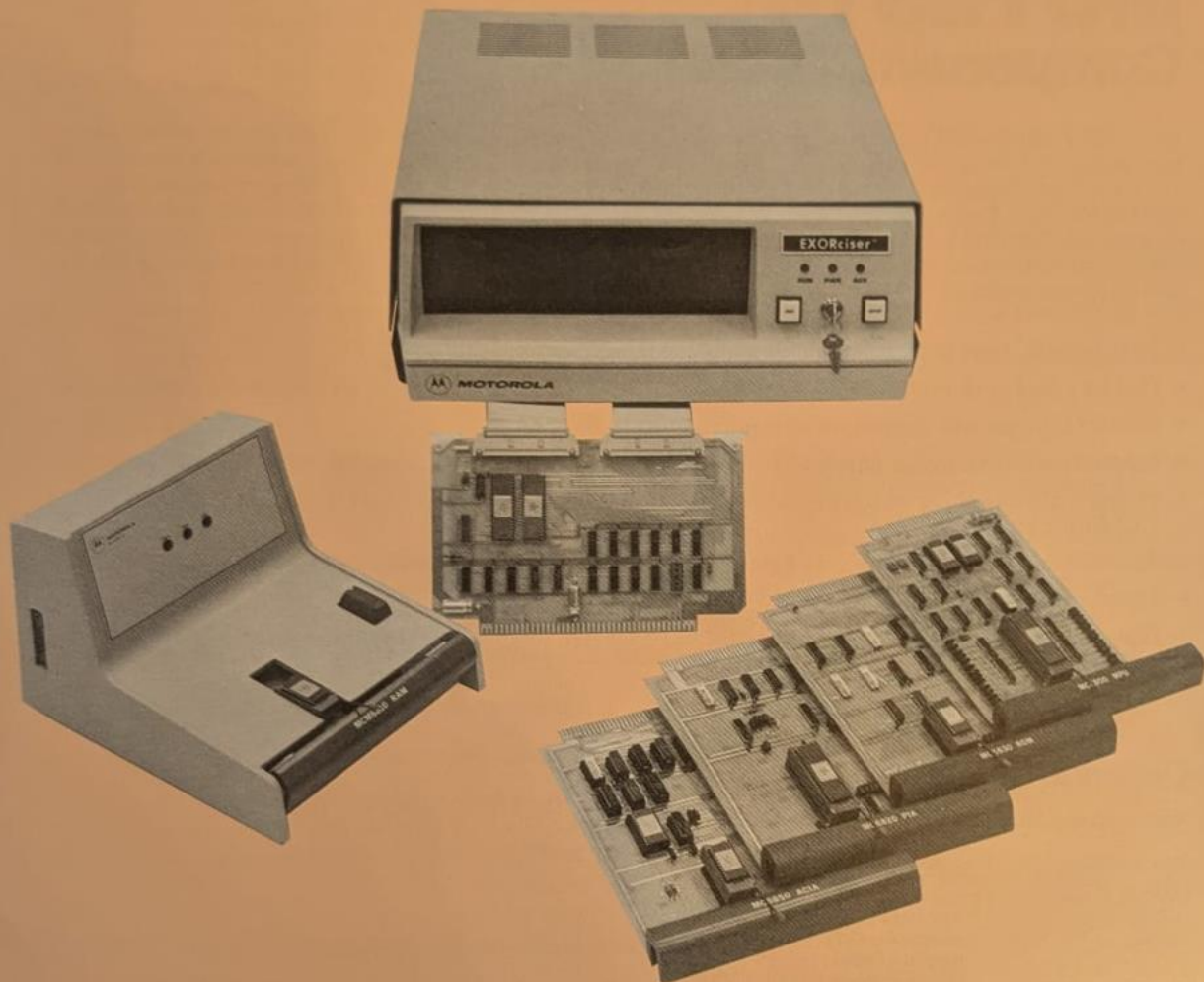

# **MEX68CT MOTEST-I Component Tester**

# MEX68CT MOTEST-I Component Tester

MOTEST-I (MEX68CT) is a dynamic LSI tester that provides the EXORciser with the capability of testing the M6800 microcomputer family of parts in an environment that closely approximates the end use conditions. Presently, MOTEST-I has the capability of testing the MC6800 Microprocessor Unit (MPU), MC6820 Peripheral Interface Adapter (PIA), MC6850 Asynchronous Communications Interface Adapter (ACIA), MCM6810 128 x 8 Bit Static Random Access Memory (RAM), and MCM6830 1024 x 8 Bit Read Only Memory (ROM). Using the Universal ROM card, additional TTL-compatible ROMs can also be accommodated.

- Functionally tests M6800 microcomputer family of parts in real time
- Can be adapted to test other devices: memories, TTL parts, CMOS parts, and other microprocessors
- One EXORciser will control up to eight test heads
- Uses internal EXORciser power (+5 Vdc) or external power (determined by user)
- Provides statistical log which indicates PART TYPE, TOTAL TESTED, TOTAL FAILED, and % GOOD for each test head
- Provides interlocking between test program and personality card in the test head
- Optional footswitch control
- Optional extender allows personality card to be located in environmental chamber for environmental testing
- PASS/FAIL indications

## Ordering Information

When ordering MOTEST-I, the user selects the options he requires.

Part Number	Description
MEX68CT A,B,D	Component Tester Test Head (1) Control Card (1) Interface Cables (2) Executive Program (1)

## Options

Part Number	Description
MEX68CT2 A,B,D	MPU (MC6800) Personality Card, Test Program
MEX68CT3 A,B,D	PIA (MC6820) Personality Card, Test Program
MEX68CT4 A,B,D	ACIA (MC6850) Personality Card, Test Program
MEX68CT5 A,B,D	ROM (MCM6830) Personality Card, Test Program
MEX68CT6	ROM Universal Personality Card, Test Program
MEX68CT7 A,B,D	RAM (MCM6810) Personality Card, Test Program
MEX68CT10	Footswitch

A Suffix – Cassette, B – Paper Tape, D – Diskette

# Component Testing

*Control is returned to the Executive Program due to either PASS or FAIL.*

## MPU Testing

The following tests are performed on the MPU:

- The test program is loaded into the two resident 128 byte RAMs.
- Control is transferred to the MPU under test, and the "instruction set" (1) is executed. Termination is a WAI causing BA to go true.
- The EXORciser looks for BA from the MPU under test or time out, whichever comes first.
- NMI and IRQ are independently pulled causing the MPU to go to another WAI in the program, depending upon the state of the interrupt mask described in the following step.
- Modification of the program changes the running address from 00XX<sub>16</sub> to 55XX<sub>16</sub>. The instruction CLI is substituted for SEI on this pass.
- Assuming successful execution of the first pass, as evidenced by returning control to the EXORciser and reading the memory and comparing the results to known check sums, the program is modified.
- The program is now run again and the results checked.
- The program is again modified to run at 2AXX<sub>16</sub>. The instruction SEI is exchanged for CLI on this pass.
- The program is now run again and the results checked.
- The instructions not previously executed, as described in footnote (1), are now run. These include stack and index register codes, subroutine jumps and returns flagged by the index register.
- Upon successful completion of the program that has just run, TSC is enabled by the EXORciser causing the MPU under test to execute the code in location FFFF<sub>16</sub>.
- NMI is then enabled, vectoring the MPU to another WAI instruction.
- Memory is again checked for successful execution of the second program.

## PIA Testing

The following tests are performed on the PIA:

- Test Reset Line clears all PIA registers.
- Test ability to read/write Data Direction Registers.
- Test A-Data Register as an output while driving B-Data Register as an input.
- Test A-side Chip Selects and B-side Write Enable.
- Test B-Data Register as an output while driving A-Data Register as an input.
- Test B-side Chip Selects and A-side Write Enable.
- Test three-state capability of CA2 and CB2.
- Test CA1 and CB1 as interrupt input lines.
- Test CA2 as an output line while CB2 is an input line.
- Test CB2 as an output line while CA2 is an input line.

## ACIA Testing

The following tests are performed on the ACIA:

- Test Master Reset.
- Test ACIA for ability to transmit and receive data at 110 baud.
- Test ACIA for ability to transmit and receive data at 5200 baud.
- Test ACIA at different word lengths and parity selections using 500 kHz clock rate.
- Test for Transmit Interrupt and double buffering capability.
- Test Break.
- Test Ready to Send, RTS.
- Test Clear to Send, CTS.
- Test Data Carrier Detect, DCD.
- Test Receive Interrupt.
- Test Overrun Error.
- Test Framing Error.
- Test Chip Selects.
- Test False Start Bit Detection.
- Test Parity Error Detection.

## RAM Testing

The following tests are performed on the RAM:

- Walking Address test.
- Bit pattern AA R/W test.
- Bit pattern 55 R/W test.
- Galloping Read test.
- Galloping Write test.
- Walking Bit Pattern tests.

10000000	00100000	00001000	00000010
01000000	00010000	00000100	00000001

- Test Chip Selects.

## ROM Testing

The following tests are performed on the ROM:

- The message flag is tested. If the flag is a one, the ROM is read, and its contents are saved to be used as a reference pattern. The flag is then set to a zero. If the flag is a zero, the ROM is tested.
- The Chip Selects are enabled. The ROM is read, and its contents are compared to the reference pattern.
- One Chip Select at a time is disabled. The ROM is read to test the function of the respective Chip Select.

The following tests are then performed:

(1) The instruction set is incremented from 01 "NOP" to FF "STX". All undefined codes, index modification codes, JSR, RTI, stack or stack modification codes are omitted in the valid OP code file and tested separately.

# MEX68CT MOTEST-I

## General Description

The MOTEST-I system requires an EXORciser containing an MPU Module, Debug Module, Baud Rate Module, and the required memory. The memory size is determined by the number of device types being tested. MOTEST-I, itself, consists of a control card which plugs into the EXORciser, interface cables, test head, Executive program, test programs and a personality card designed for each particular part. One EXORciser will control up to eight test heads without any restriction on the mix of parts being tested. When setting up your test system, it is important to remember that each test head requires a control card and a set of interface cables to connect the test head to the EXORciser. To set up the system, the interface cables are connected to the control card, and the control card is then inserted into the EXORciser. The other ends of the interface cables are connected to the test head. If external voltages are required, they can be connected to the external power jack located on the side of the test head. To test a part, the user simply selects and inserts the particular personality card into the test head, loads the Executive and appropriate test program (using the LOAD function of EXbug) into the EXORciser, and MOTEST-I is ready to evaluate the device. The user now installs the device to be evaluated into the test socket located on the personality card, presses the TEST switch and monitors the indicators to see if the part has passed or failed.

## System Software

MOTEST-I system software consists of one Executive program and a test program for each personality card.

**EXECUTIVE** – The Executive performs the function of initializing and polling the control cards for a start test interrupt, verifying the device/test program interlock, controlling power to device under test so that it can be installed and removed with power off, providing a statistical log on request, and providing a command structure to aid setup.

**TEST PROGRAM** – The test program, upon receiving control from the Executive program, performs the following functions: calculates the test device address, sets up the control PIAs to perform the test, and sequentially tests each parameter of the test device. Control is returned to the Executive program as a result of a PASS or FAIL indication.

# MEX68CT MOTEST-I Component Tester

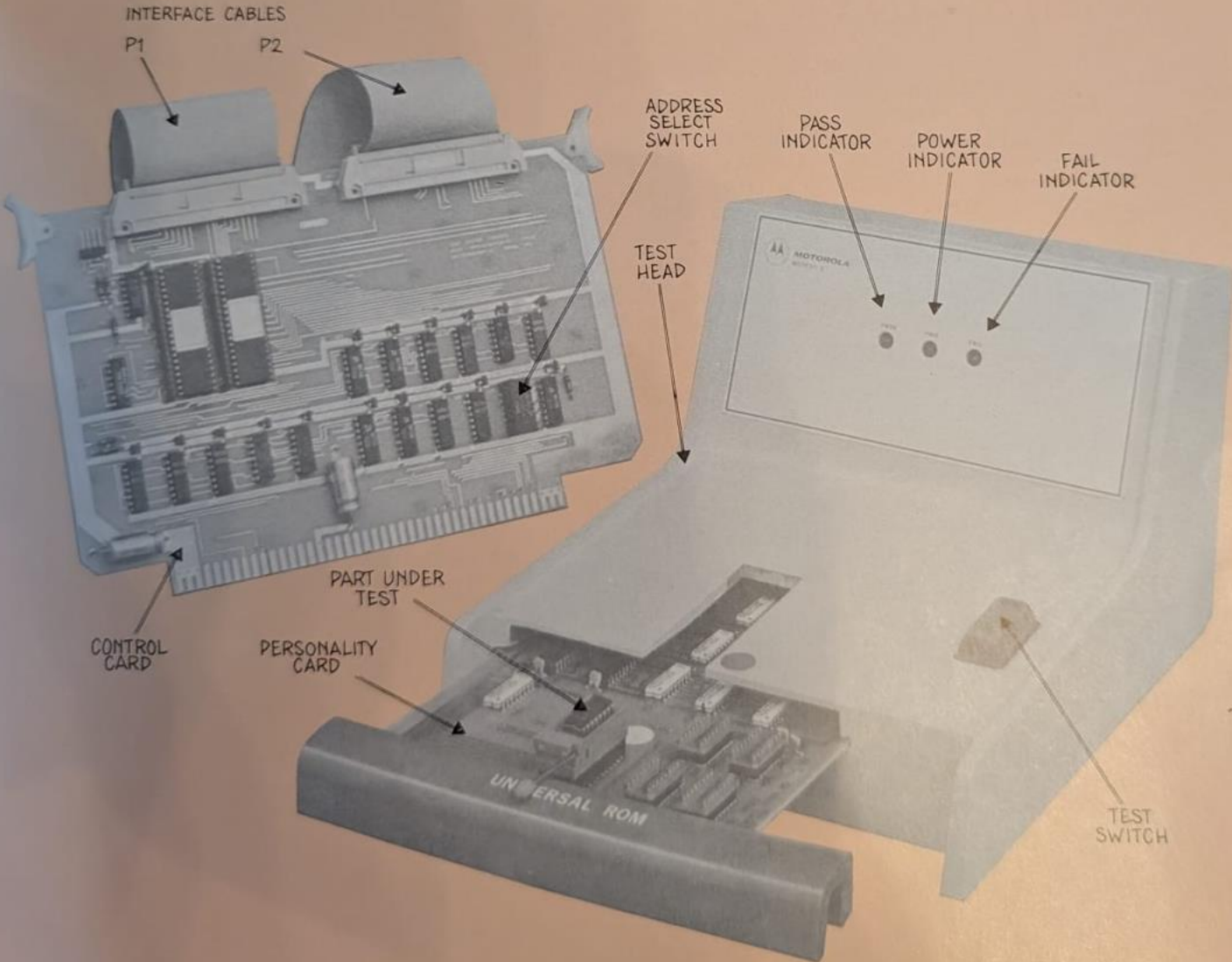
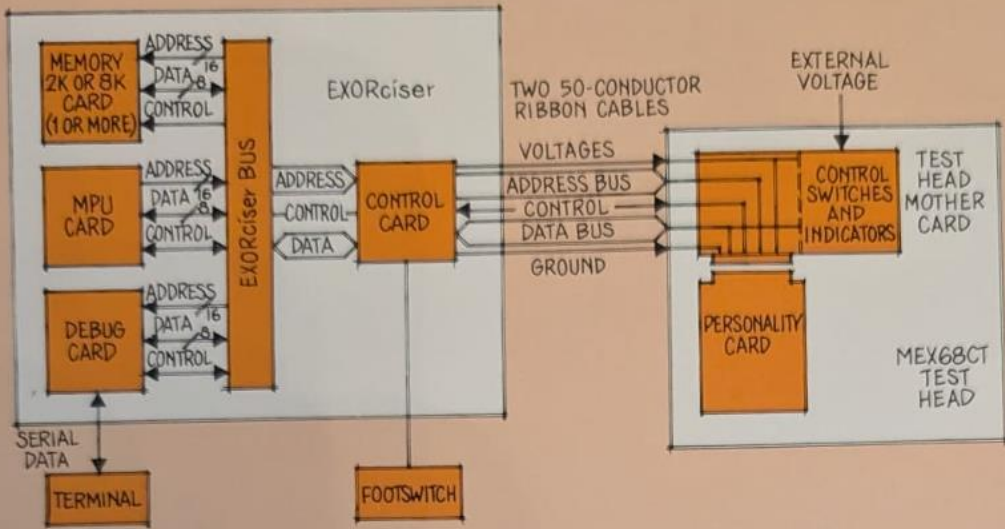



**MOTOROLA Semiconductor Products Inc.**

BOX 20912 • PHOENIX, ARIZONA 85036 • A SUBSIDIARY OF MOTOROLA INC.

1 100 876 100000 1100 0000

0001 000



# MEX68PP1 PROM Programmer Module

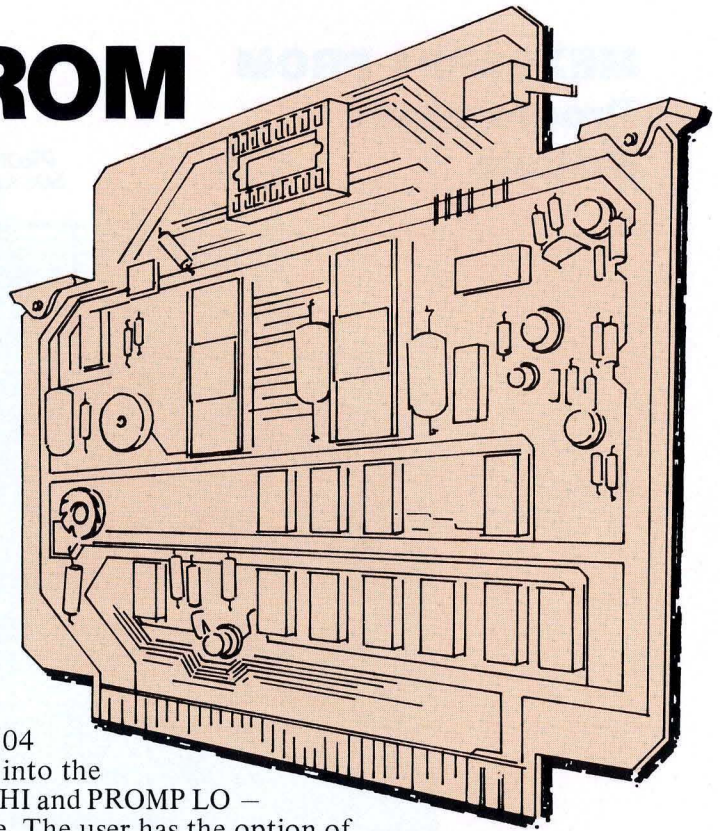

- Mounts directly into the M6800 EXORciser
- Program compatible with the EXORciser's EXbug Firmware
- Programs 2704 and 2708 EPROM devices
- EPROM program verification and compare capability
- Capable of moving data from the EPROM to EXORciser memory
- Capable of moving a block of data from one memory location to another
- All programming activities entered and controlled by the EXORciser

The MEX68PP1 PROM Programmer Module provides the EXORciser with the capability of programming 2704 and 2708 EPROM devices. This module plugs directly into the M6800 EXORciser bus and its two programs – PROM HI and PROM LO – are compatible with the EXORciser's EXbug Firmware. The user has the option of selecting and locating the PROM program into the EXORciser RAM locations that do not conflict (using the same addresses) with the user's program. That is, if the user has his program loaded in the upper portion of memory, he selects and loads the PROM LO program into the EXORciser.

The PROM Programmer Module with its software enables the EXORciser to program an EPROM device, to verify the data in the EPROM, to transfer data from the EPROM to the EXORciser's RAM memory, and to transfer blocks of data from one memory location to another.

## Specifications

Programs EPROM devices	2704 and 2708
Average Programming Time: 2704	0.57 minute
2708	1.54 minutes
Input Control Signals	TTL Voltage Compatible
Logic "0"	0.0-0.8 V
Logic "1"	2.0-5.25 V
Address Bus and R/W	
Logic "0"	0.0-0.5 V
Logic "1"	2.4-5.25 V
Off-State Leakage Current	-40 $\mu$ A
Data Bus	Three-state TTL voltage compatible
Input Logic "0"	0.0-0.8 V (-200 $\mu$ A at 0.4 V)
Input Logic "1"	2.0-5.25 V (25 $\mu$ A at 5.25 V)
Output Logic "0"	0.0-0.5 V (40 mA at 0.5 V)
Output Logic "1"	2.6-5.25 V (-10 mA at 2.6 V)
Output Off-State Leakage Current	100 $\mu$ A at 2.6 V
Power Requirements	+5 Vdc @ 800 mA
	+12 Vdc @ 300 mA during programming
	-12 Vdc @ 50 mA
Operating Temperature	0 <sup>o</sup> to 70 <sup>o</sup> C
Physical Dimensions (W x H x T)	9.75 x 7.50 x 0.062 in.

## PROM Programmer Module Options

Option	Part No.	Description
1	MEX68PP1A	PROM Programmer Module with its software on cassette
2	MEX68PP1B	PROM Programmer Module with its software on paper tape
3	MEX68PP1D	PROM Programmer Module with its software on diskette

# MEX68PP1 PROM Programmer Module

**Option**

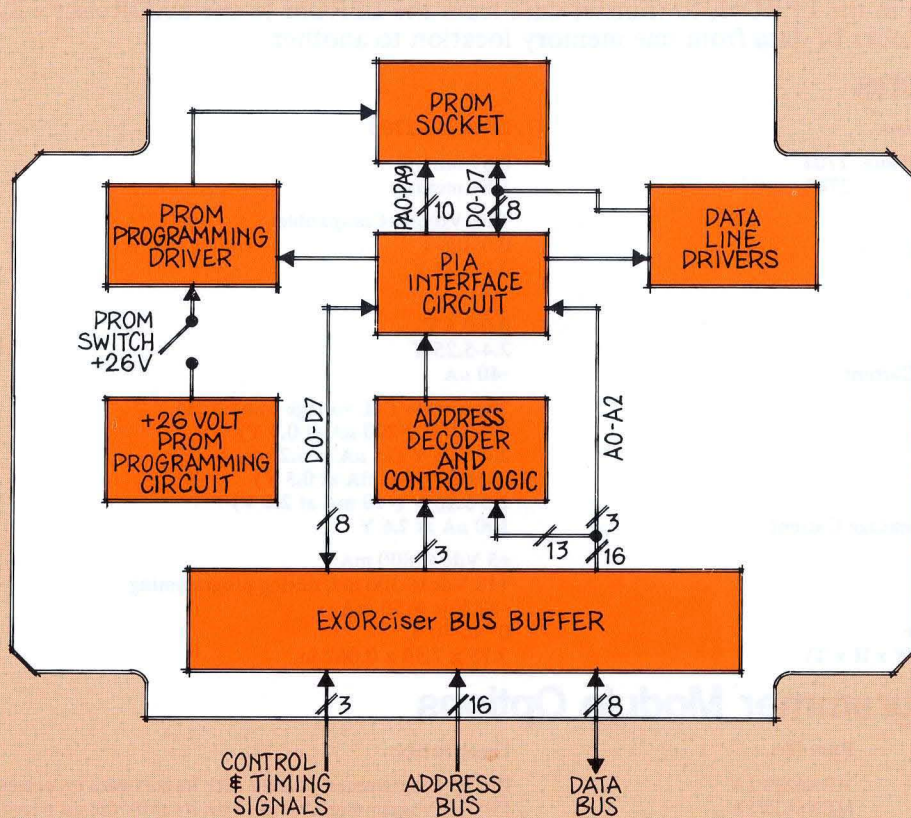
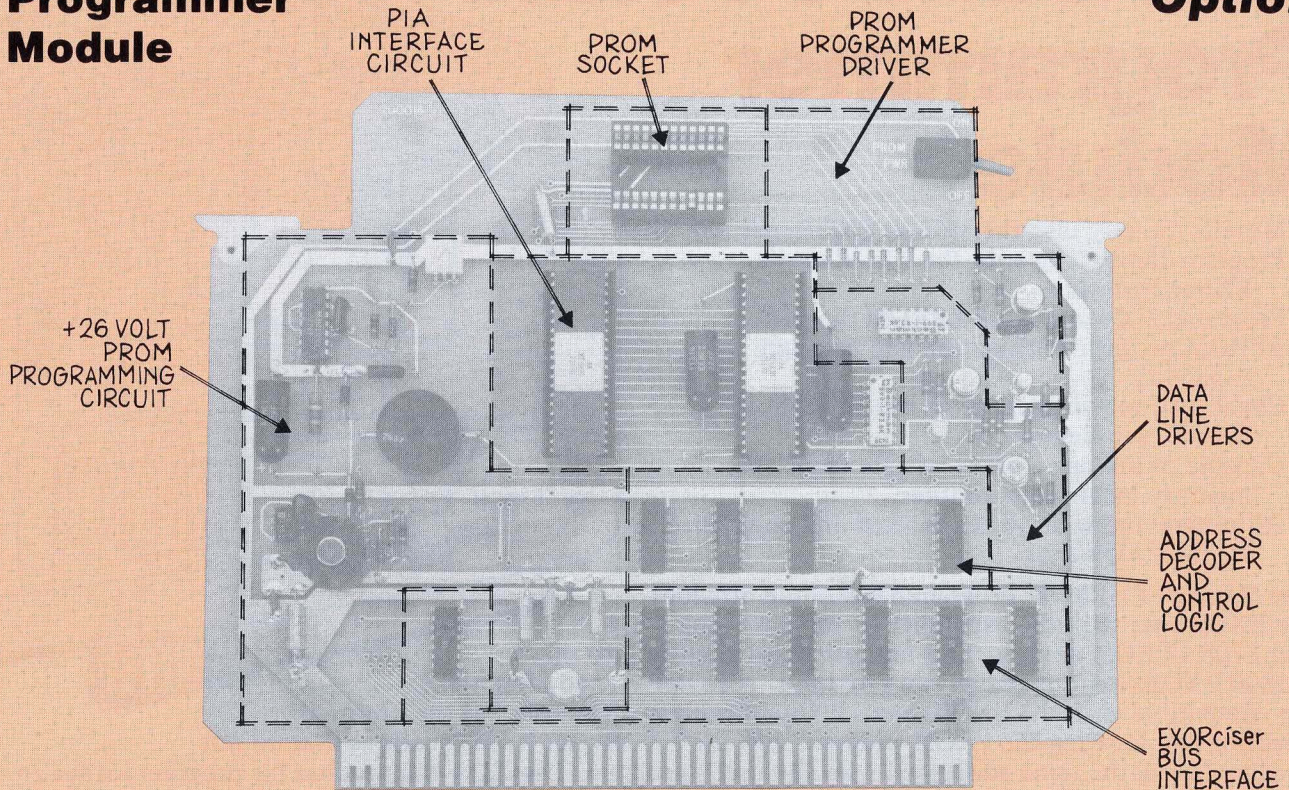

**MOTOROLA Semiconductor Products Inc.**

BOX 20912 • PHOENIX, ARIZONA 85036 • A SUBSIDIARY OF MOTOROLA INC.

10211 PRINTED IN USA 5-76 IMPERIAL L1790 857297 20K



**MOTOROLA**

# MEX68RR EROM/RAM Module

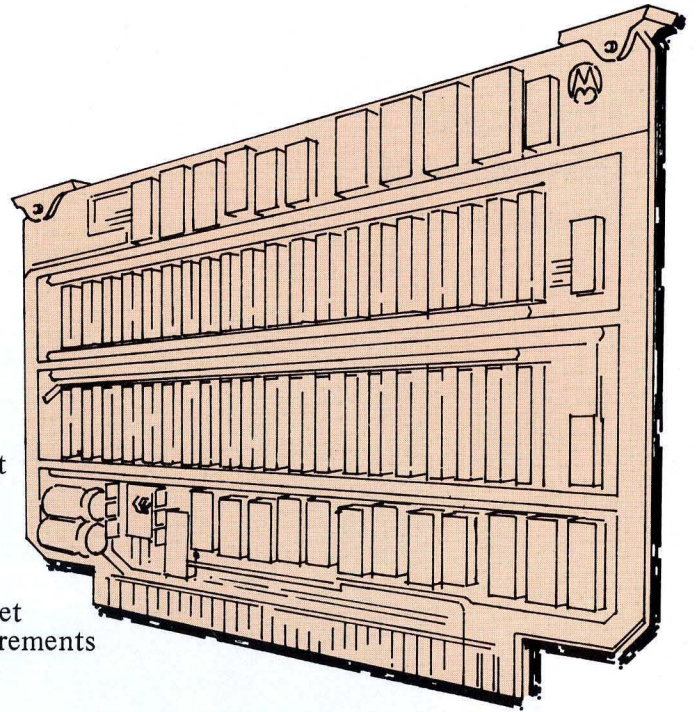

- Up to 16,384 x 8 bits of ROM/PROM memory in four 4K byte arrays
- Utilizes user-programmed 1024 x 8 bit or 512 x 8 bit ROM/PROM devices (four devices per array)
- Switch selectable base memory address for each memory array
- Switch selectable read enable for each installed ROM and read disable for each unused ROM socket
- Up to 512 x 8 bits of RAM memory in 128 byte increments
- TTL voltage compatible
- Bus drive capability

The MEX68RR EROM/RAM Module provides the EXORciser with up to 16,384 bytes of ROM/PROM memory and up to 512 bytes of RAM memory. Four sockets accommodate up to four MCM6810 128 x 8 bit RAM memory devices. The RAM memory is assigned to memory locations 0000<sub>16</sub> through 01FF<sub>16</sub> (the bottom of the EXORciser's memory). However, this array consumes the lower 1024 bytes of the EXORciser's memory (0000<sub>16</sub> through 03FF<sub>16</sub>) although the maximum memory capability is 512 bytes.

The ROM memory section is organized into four memory arrays with four sockets per array; therefore each array is capable of mounting up to 4K bytes of ROM or PROM memory. The user installs his programmed ROMs into the desired sockets, and selects the address for each array by proper setting of each array's base memory address switch.

The 16 individual ROM read switches permit the user to enable the ROM/PROM devices to be read and disable the sockets not being used. Unless disabled by this switch, each ROM/PROM socket occupies 1024 bytes of memory whether the device mounted in the socket is a 512 byte or 1024 byte device. The memory locations assigned to the disabled sockets may be assigned to other memory or peripheral devices in the user's system.

## Specifications

(Note: Positive current flow is defined as flowing into the terminal, negative current flow as flowing from the terminal.)

### Memory Mounting Capability

RAM  
ROM

Up to four MCM6810 or equivalent RAM devices (up to 512 bytes)  
Up to 16 MCM68708 or equivalent EROM devices (up to 16K bytes)

### Memory Organization

RAM  
ROM

Up to 512 x 8 bits organized into one array. (The array consumes 1024 x 8 bits of memory.)  
Up to 16,384 x 8 bits organized into four arrays (four sockets per array), with up to 4096 x 8 bits per array. Unless disabled, each socket consumes 1024 x 8 bits of memory whether it contains a 512 x 8 bit or 1024 x 8 bit ROM/PROM device.

### Input Signals

Logic "0"  
Logic "1"

TTL voltage compatible  
0.0-0.85 V (-200  $\mu$ A max at 0.4 V)  
2.0-5.25 V (25  $\mu$ A max at 5.25 V)

### Data Bus

Input Logic "0"  
Input Logic "1"  
Output Logic "0"  
Output Logic "1"

Three-state TTL voltage compatible  
0.0-0.85 V (-200  $\mu$ A max at 0.4 V)  
2.0-5.25 V (25  $\mu$ A max at 5.25 V)  
0.5 V max at 40 mA through a resistor to V<sub>CC</sub>  
2.6 V min at -10 mA through a resistor to ground

Output Off-State Leakage Current

100  $\mu$ A max at 2.6V

### Operating Temperature

0 to 70° C

### Power Requirements

+5 Vdc at 1A max  
+12 Vdc at 1A max  
-12 Vdc at 1A max

### Physical Dimensions

W x H x T

9.75 x 5.75 x 0.062 in.

# MEX68RR EROM/RAM Module

Option

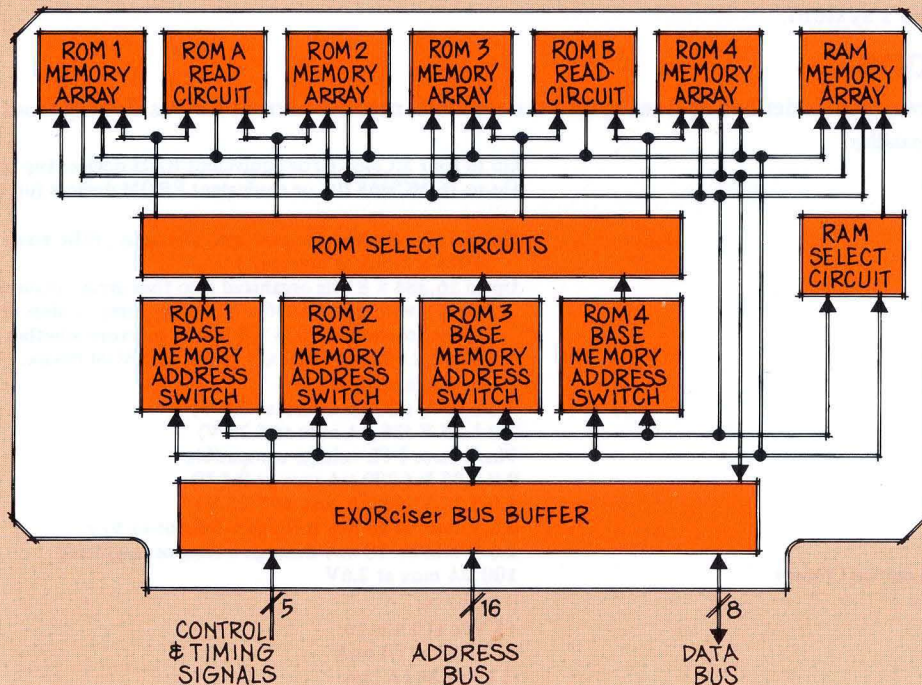
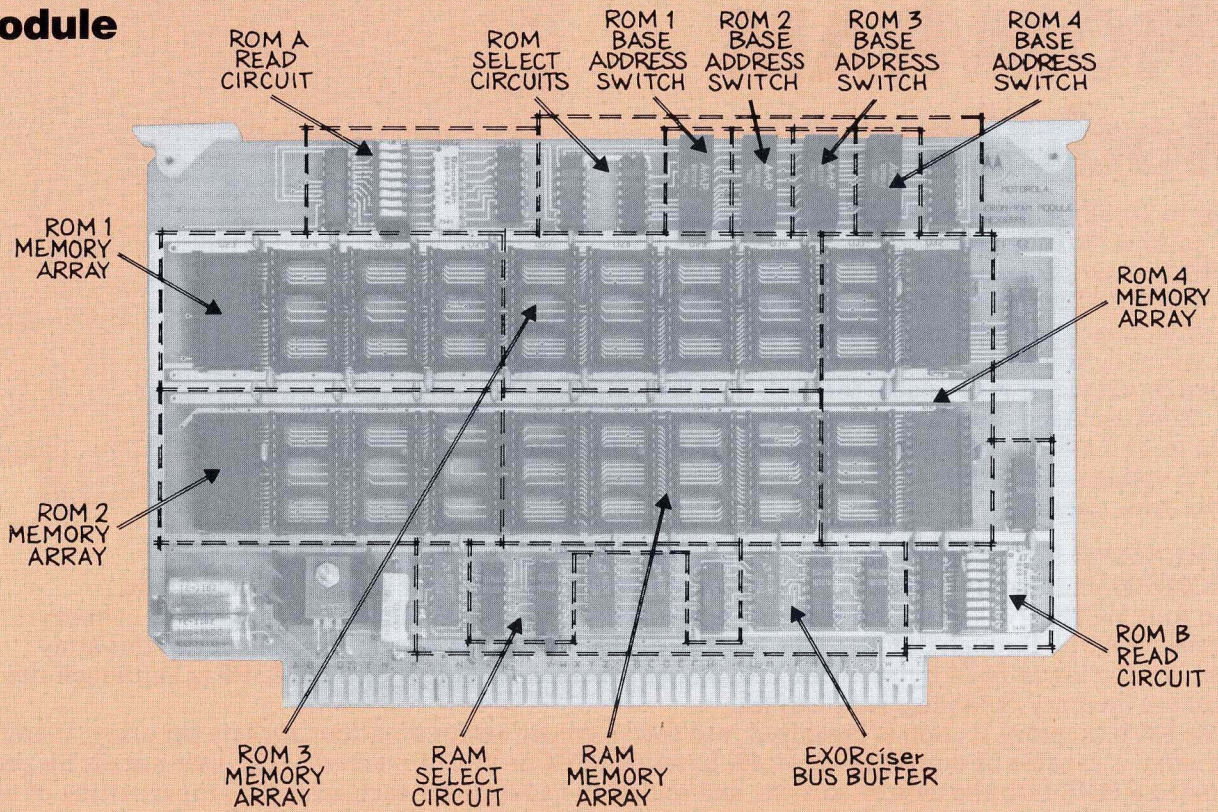

**MOTOROLA Semiconductor Products Inc.**

BOX 20912 • PHOENIX, ARIZONA 85036 • A SUBSIDIARY OF MOTOROLA INC.

10211 PRINTED IN USA 5-76 IMPERIAL LITHO 857297

204

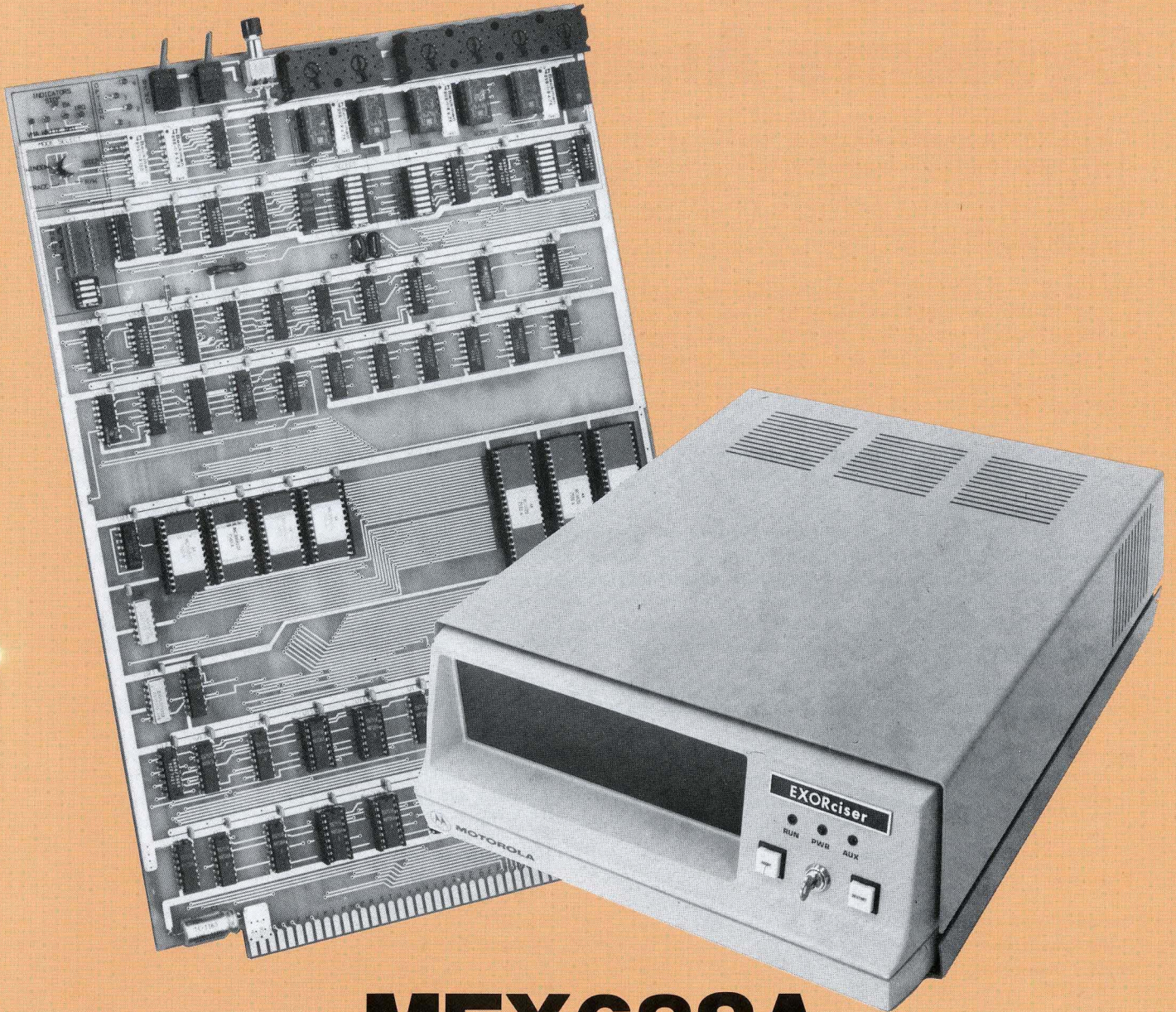

# **MEX68SA**

## **Systems Analyzer**

### **For System Development and Troubleshooting**

# MEX68SA

## Systems Analyzer

The MEX68SA Systems Analyzer provides an efficient and economical means of monitoring, analyzing, and troubleshooting M6800 Microprocessor Systems. This module connects directly into the MPU's bus and permits the user access to the operations being performed inside of his MPU. With a minor modification to the MPU's VMA signal, the Systems Analyzer is capable of performing the following functions:

- Stop the MC6800 MPU on detecting the selected compare conditions
- Step through the MPU's program
- Examine and, if required, change the contents in the MPU system's memory
- Trace through the MPU's program
- Monitor and record (takes a snapshot of) the MPU's operation during a selected portion of the MPU's program
- Print a hard copy of the data stored in the Systems Analyzer memory during the snapshot operation

The Systems Analyzer consists of six major blocks and has six modes of operation. The six major blocks are the Switch and Indicator Section, the Compare Section, the Memory Section, the Bus Buffer Section, the Hard Copy Interface Section, and the Control Section. The Control Section decodes the setting of the MODE SELECT switch and determines the module's mode of operation: MPU Run Mode, Step Mode, Standby Mode, Read/Write Mode, Trace Mode, and Window Mode. The module performs its snapshot operation in the Trace and Window Modes.

## Specifications

(Note: Positive current flow is defined as flowing into the terminal, negative current flow as flowing from the terminal.)

### Signal Characteristics

Input Logic "0"  
Input Logic "1"  
Output Logic "0"  
Output Logic "1"  
Output Off-State Leakage Current

0.0-0.85 V (-200  $\mu$ A max at 0.4 V)  
2.0-5.25 V (25  $\mu$ A max at 5.25 V)  
0.5 V max at 40 mA through a resistor to  $V_{CC}$   
2.6 V min at -10 mA through a resistor to ground  
100  $\mu$ A max at 2.6 V

### Memory Size

128 x 32 bits of random access memory consisting of four MCM6810 RAM devices

### Operating Temperature

0 to 70°C

### Power Requirements

+5 Vdc @ 2.75 A

### Physical Dimensions

W x H x T

9.75 x 14.0 x 0.062 in.

# Systems Analyzer Circuitry

## Switch and Indicator Section

This section provides the user with a means of entering the selected compare conditions and of monitoring the status of the MPU bus. The switch portion of this circuitry consists of four hexadecimal address switches, two hexadecimal data switches, and a connector to permit the user to insert up to four optional input signals that he wishes to monitor. The indicator portion of this circuit consists of four hexadecimal address displays, two hexadecimal data displays, and nine LED displays. The LEDs display the status of the MPU (running or halted), the status of the four MPU control signals (R/W, VMA, IRQ, and NMI), and the status of the four user-selected optional input signals to the module.

## Compare Section

This section, when enabled, compares the MPU bus signals with the output of the hexadecimal switches in the switch and indicator section to detect the selected compare conditions. A switch in each of the compare lines can be enabled or disabled to meet the selected compare conditions. On detecting these conditions, this circuit applies a compare strobe to the other sections in the module.

## Memory Section

This section consists of four MCM6810 128 x 8-bit RAM memory devices arranged into a 128 x 32-bit memory array. This memory, when enabled stores the bus status — 16 address lines, 8 data lines, VMA, R/W, IRQ, NMI, and the four user selected optional inputs — during each MPU  $\phi 2$  clock pulse. The memory is enabled to record data during the snapshot operation in the Trace and Window Modes.

## Bus Buffer Section

This section interfaces the Systems Analyzer Module into the EXORciser or the user's system. The data bus buffer devices may be changed to interface the module with a low-true or high-true system.

## Hard Copy Interface Section

This section, working with the EXORciser's EXbug Firmware, permits the user to print a hard copy of the data stored in the module's memory. If the Systems Analyzer is not working with the EXORciser, and the user wishes to use the module's hard copy capability, he is required to develop the appropriate I/O routines in his system's program.

## Control Section

This section decodes the setting of the MODE SELECT switch and determines which of the module's six modes of operation is to be used.

In the **MPU Run Mode** the Systems Analyzer is disabled and effectively removed from the user's system.

In the **Step Mode** the Systems Analyzer monitors the MPU bus and, on detecting the selected compare conditions, halts the MPU. The user now can step through the user's program.

In the **Standby Mode** the Systems Analyzer holds the MPU in the state it was placed in while the module was in the Read/Write or Step Mode.

In the **Read/Write Mode** the Systems Analyzer halts the MPU on detecting the selected compare conditions. This module now permits the user to examine and, if required, change the contents in the MPU's memory. The hexadecimal switches in the Switch and Indicator Section select the memory location to be examined and the hexadecimal data switches select the data to be written into memory.

In the **Trace Mode** the Systems Analyzer stores the MPU bus status in its memory during each  $\phi 2$  clock pulse. On detecting the selected compare conditions, the Systems Analyzer stores an additional 64 bus states and then halts the MPU. The user now can examine the 128 bus states — the 63 bus states before the selected compare conditions, the selected compare condition bus state, and 63 bus states after the selected compare conditions — recorded in the module's memory.

In the **Window Mode**, as in the Trace Mode, the Systems Analyzer stores the MPU bus states in its memory during each  $\phi 2$  clock pulse. On detecting the selected compare conditions the module stores an additional 64 bus states and then stops storing data. In this mode, however, the MPU is not halted but continues running and the user has a snapshot or window view of the operations being performed in the selected portion of his program. The user can now examine the 128 bus states within the selected window area and, if desired, print a hard copy of these bus states.

# MEX68SA Systems Analyzer

CONTROL SECTION

MEMORY SECTION

BUS BUFFER SECTION

SWITCH AND INDICATOR SECTION

COMPARE SECTION

HARD COPY INTERFACE SECTION

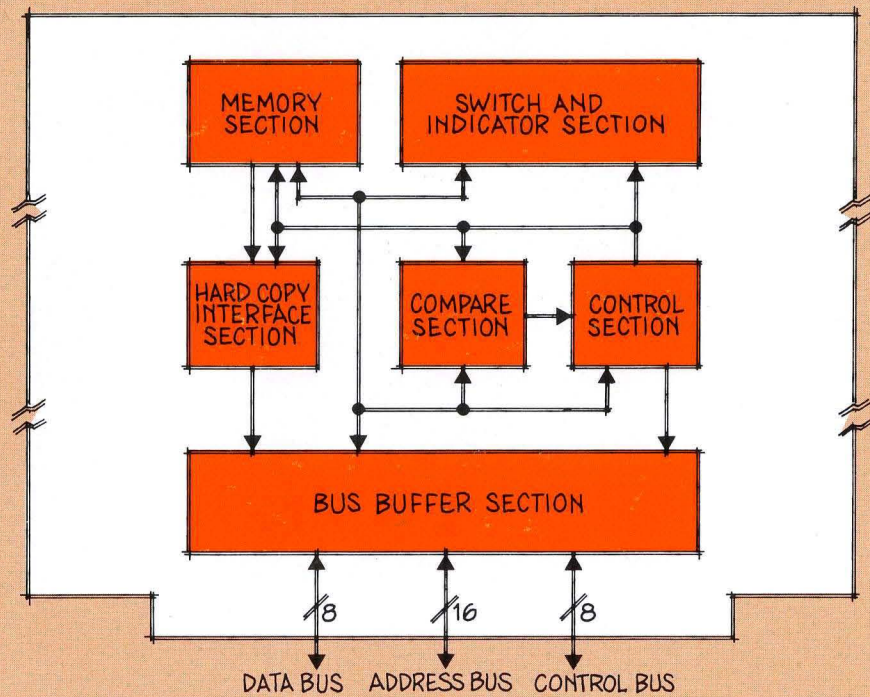
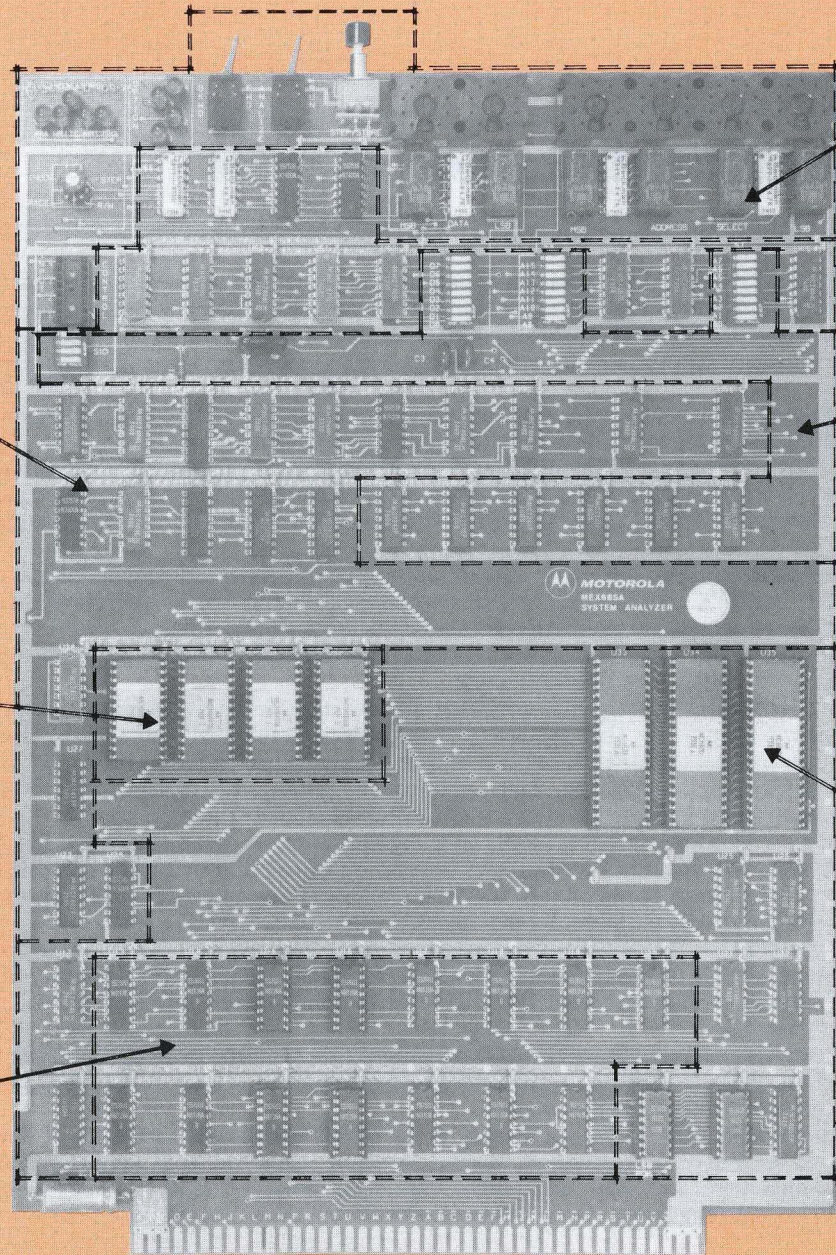

# Systems Analyzer Interface Signals

The MEX68SA Systems Analyzer Module plugs directly into the EXORciser bus or may be connected to the MPU's bus in the user's system.

**Data Bus (D0-D7) or Data Bus (D0-D7)** – These eight bi-directional lines, when enabled, provide a two-way transfer of data between the MPU Module in the EXORciser or the MPU in the user's system and the selected memory location. When the MPU has been halted, the Systems Analyzer controls the flow of data on this bus. These bus signals in the EXORciser are low true. The user can, through installing the appropriate bus device, change these signals for high true operation.

**Address Bus (A0-A15)** – These 16 lines, when enabled, transfer the selected address to the system's memory and input/output devices. When the Systems Analyzer is halted, it controls this line.

**Read/Write (R/W)** – This MPU output signal indicates whether the MPU is performing a memory read (high) or write (low) operation. The normal standby state of this line is read. Also, when the MPU is halted, this signal will be in the read state. The Systems Analyzer, in halting the MPU, gains control of this signal and can initiate a memory read or write operation.

**Valid Memory Address (VMA)** – This line, when present, indicates to the memory and peripheral devices that the address on the bus is valid. The MPU's VMA output signal must be modified to allow the Systems Analyzer Module to pull this line high and address the memory and peripheral devices when the MPU is halted.

**Phase 2 ( $\phi_2$ ) Clock Signal** – This signal is between 100 kHz and 1 MHz, and is used to synchronize the transfer of data on the data bus. This signal is controlled by the MPU clock.

**Bus Available (BA)** – This MPU output signal is normally in a low state. When activated, it will go high indicating that the MPU is available. This will occur if the  $\overline{\text{Halt}}$  line is low or the MPU is in the WAIT state as the result of executing a WAIT instruction. At such time, all the MPU three-state output drivers will go to their off or high impedance state and all other outputs to their normally inactive state. An interrupt command removes the MPU from the WAIT state. The Systems Analyzer uses this signal to indicate the status of the MPU – halted or running.

**Interrupt Request (IRQ)** – This level sensitive input, on going low, requests that an interrupt sequence be generated in the system. The MC6800 MPU will wait until it completes the current instruction that it is executing before it recognizes this request. At that time, if the interrupt mask bit in the MPU Condition Code Register is not set, the MPU will begin the interrupt sequence. The Systems Analyzer monitors this signal.

**Non-Maskable Interrupt (NMI)** – This level sensitive input, on going low, requests that an interrupt sequence be generated within the system. The MC6800 MPU will wait until it completes the current instruction that it is executing before it recognizes this request. At this time, the MPU will begin its non-maskable interrupt routine. The Systems Analyzer also monitors this signal.

**Reset** – This edge sensitive signal initiates an MC6800 MPU power-on vectored interrupt initialize routine when the user resets his systems. This signal, in addition to resetting the system's MPU, is used to reset and initialize the Systems Analyzer's MC6820 Peripheral Interface Adapter devices.

**Halt** – When this level sensitive signal is low, all activity in the MC6800 MPU will be halted. In the halt mode, the microprocessor will stop at the end of an instruction, the Bus Available signal will be at a high level, and all of the three-state lines will be in their high impedance state. The MPU's VMA signal must be modified to allow the Systems Analyzer Module access to the MPU system's memory and peripherals when it has halted the MPU.



**MOTOROLA Semiconductor Products Inc.**

BOX 20912 • PHOENIX, ARIZONA 85036 • A SUBSIDIARY OF MOTOROLA INC.



# MEX68USE

## User System Evaluator (USE)

The MEX68USE User System Evaluator (USE), working with the M6800 EXORciser and the optional MEX68SA Systems Analyzer Module, provides the user with the complete systems development tool. That is, USE extends all of the EXORciser's EXbug functions and all of the optional Systems Analyzer functions into the user's system. The USE-equipped EXORciser provides the designer with the capability of configuring an emulation of his M6800 microprocessor system in the EXORciser, external to the EXORciser, or a combination of EXORciser-mounted modules working with the user's external system. The designer also can develop his system software and firmware on the EXORciser and can use the USE-equipped EXORciser to debug his system hardware and software. In fact, a USE-equipped EXORciser can even be used to test and evaluate the user's production systems.

- Extends the EXORciser EXbug functions into the user's system.
- Operates from the user's system clock or from the EXORciser's internal clock.
- Permits the user to share the EXORciser's memory and input/output modules with the user's system.
- Extends the optional Systems Analyzer Module's functions into the user's system when the Systems Analyzer is used with the EXORciser.
- Provides convenient block/fault isolation.
- Uses present commands — no new protocol to be learned.

USE consists of three assemblies: the USE Processor Module, the USE Intercept Module, and the USE Cable and Buffer Assembly. The *USE Processor Module* is used in place of the MEX6800 MPU Module in the EXORciser and provides the following functions:

- Shares its MC6800 MPU device between the EXORciser and the user's system.
- Provides the EXORciser internal clock circuitry.
- Provides the option of using the EXORciser clock within the EXORciser.
- Enables the overall system — user's system and EXORciser — to operate with the user's system clock.
- Interfaces the MC6800 MPU address, data, and control signals with the EXORciser bus.
- Interfaces the MC6800 MPU address, data, and control signals with the user's system via the USE Cable and Buffer Assembly.
- Interfaces selected MC6800 MPU signals ( $\overline{IRQ}$ ,  $\overline{NMI}$ , HALT, VMA, and BA) with the optional Systems Analyzer Module via the USE Intercept Module.

The *USE Intercept Module* plugs directly into the EXORciser bus and is used to mount the optional Systems Analyzer Module. A cable assembly couples the selected control signals between the Systems Analyzer and the USE Processor Module.

The *USE Cable and Buffer Assembly* connects the USE Processor Module into the user's system. A 40-pin connector on this assembly plugs into the MPU socket in the user's system permitting the USE Processor Module's MPU to control the operation of the user's system. In this application everything within the EXORciser appears to be within the MPU in the user's system. Through special jumper connections, this assembly also can transfer the timing signals required by the dynamic memories in the EXORciser to operate with the user's system clock. In addition, the USE Cable and Buffer Assembly buffers the transferred signals.

# MEX68USE User System Evaluator (USE)

## Specifications

Microprocessor MC6800 MPU

Word Size  
Data 8 bits  
Address 16 bits  
Instruction 8, 16, or 24 bits

Instruction Set 72 variable length instructions

Addressing Modes Seven address modes – Direct, Relative, Immediate, Indexed, Extended, Implied, and Accumulator

Memory Size Capability 65,536 bytes with the EXORciser EXbug Firmware (when used) using 4K bytes. Addresses EXORciser ROM, RAM, and I/O and user's system ROM, RAM, and I/O in any combination.

Clock Signals Switch Selectable  
Crystal controlled 1 MHz clock with capability to work with dynamic and slow memories. Operates in the EXORciser system.  
or  
User's system clock operating in the EXORciser and the User's system.

Operating Temperatures 0 to 70° C.  
Power Requirements +5 Vdc at 1.5 A

Physical Characteristics

USE Processor Module  
Width 9.75 in.  
Height 5.75 in. above connector  
Board Thickness 0.062 in.

USE Intercept Module  
Width 9.75 in.  
Height 1.875 in.  
Board Thickness 0.062 in.  
Cable Assembly Length 1 ft.

USE Cable and Buffer Assembly  
Case Height 0.875 in.  
Case Length 7.50 in.  
Case Width 4.32 in.  
Cable Assembly Length 2 cables 5 ft. each  
1 cable 13 in.

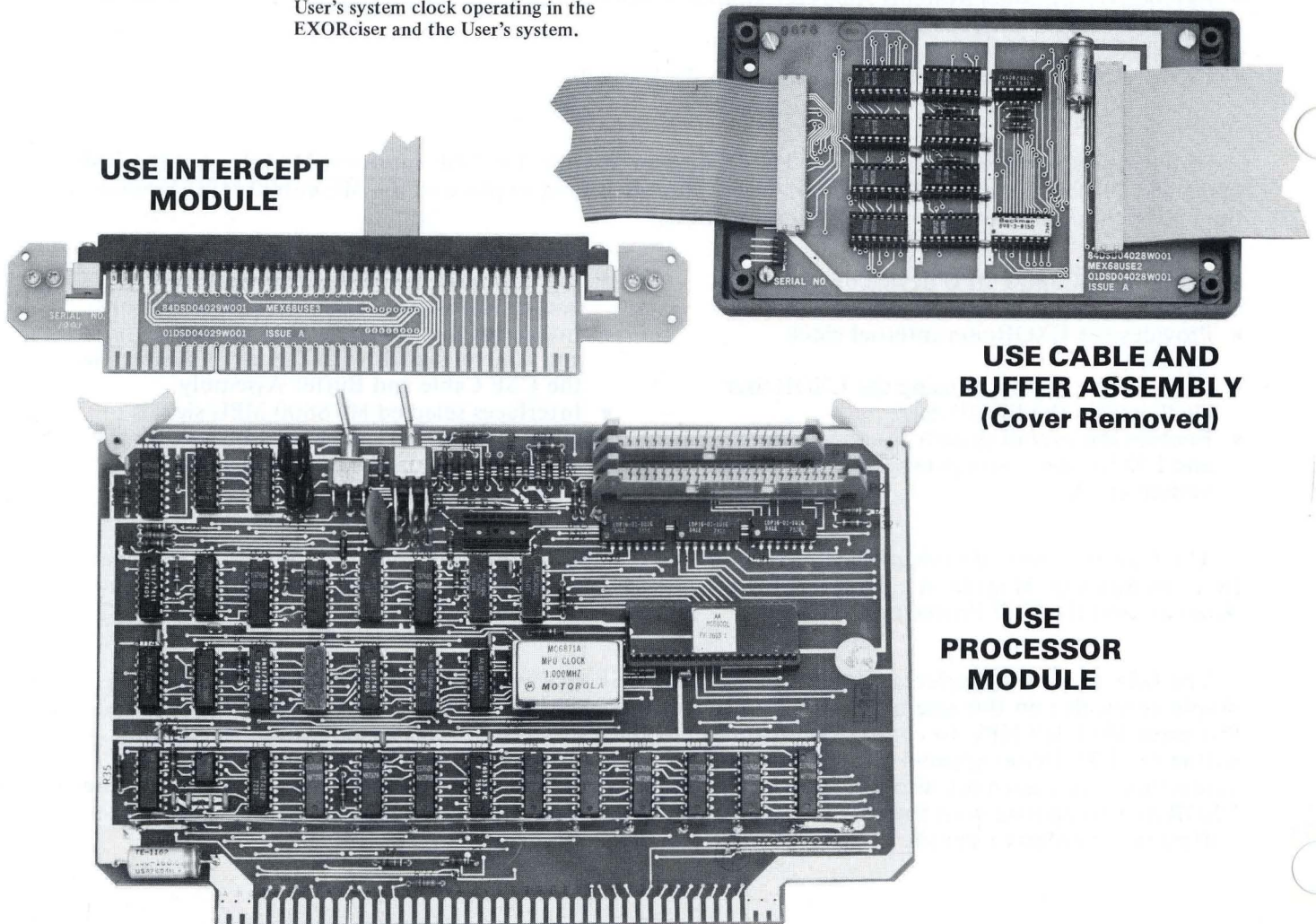

**USE INTERCEPT  
MODULE**

**USE CABLE AND  
BUFFER ASSEMBLY  
(Cover Removed)**

**USE  
PROCESSOR  
MODULE**



**MOTOROLA Semiconductor Products Inc.**

BOX 20912 • PHOENIX, ARIZONA 85036 • A SUBSIDIARY OF MOTOROLA INC.

10211 PRINTED IN USA 7-76 IMPERIAL LTHO 858554

# MEX68WW

## Wirewrap Module

**Option**

- Standard size EXORciser plug-in module
- Compatible with the EXORciser bus
- Standard pin spacing for 14, 16, and 24-pin wirewrap sockets
- Provisions for two 50-pin flatribbon cable connectors
- Permits user to incorporate his custom circuits into the EXORciser emulated system

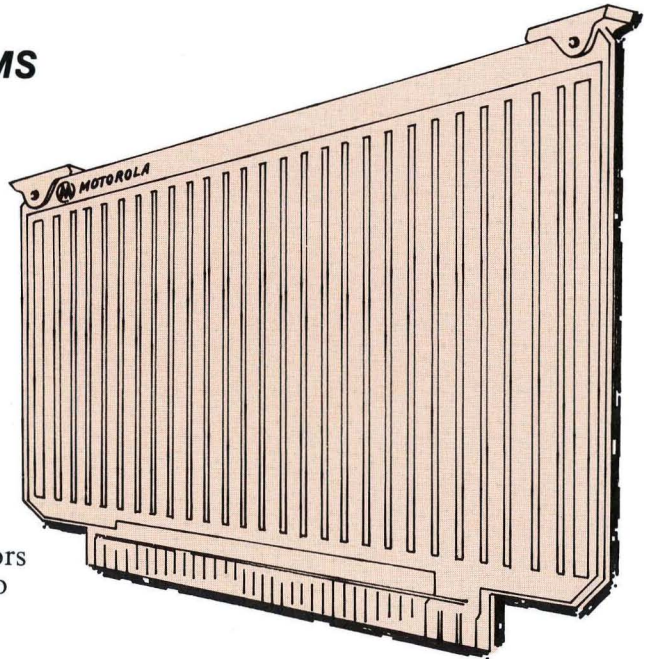

The MEX68WW Universal Wirewrap Module permits the user to construct and incorporate his custom circuits into an EXORciser emulated system. Incorporated on the module are the power bus and the ground bus printed wiring runs. Also, the module has standard pin spacing and provisions for 14, 16, and 24-pin wirewrap sockets and for two 50-pin wirewrap flatribbon cable connectors.

## Specifications

Physical Dimensions:  
W x H x T                      9.75 x 5.75 x 0.062 in.

# MEX68XT

## Extender Module

**Option**

- Extends any EXORciser plug-in module for testing, trouble-shooting, and debugging
- Interfaces with all EXORciser plug-in modules
- Compatible with the EXORciser bus
- Provides clip-on test points for all EXORciser bus signals

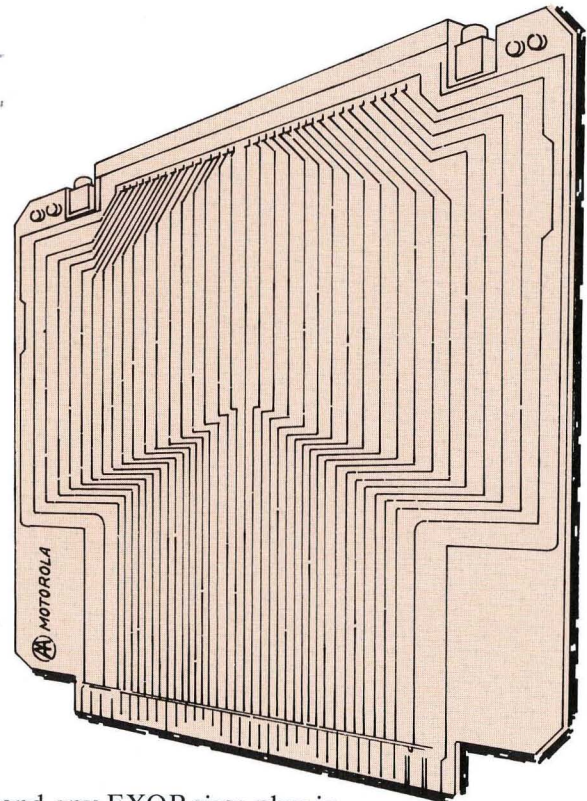

The MEX68XT Extender Module enables the user to extend any EXORciser plug-in module for servicing, testing, trouble-shooting, and debugging. This module provides clip-on test points, giving the user access to the EXORciser bus.

## Specifications

Physical Dimensions:  
W x H x T                      9.75 x 9.00 x 0.062 in.

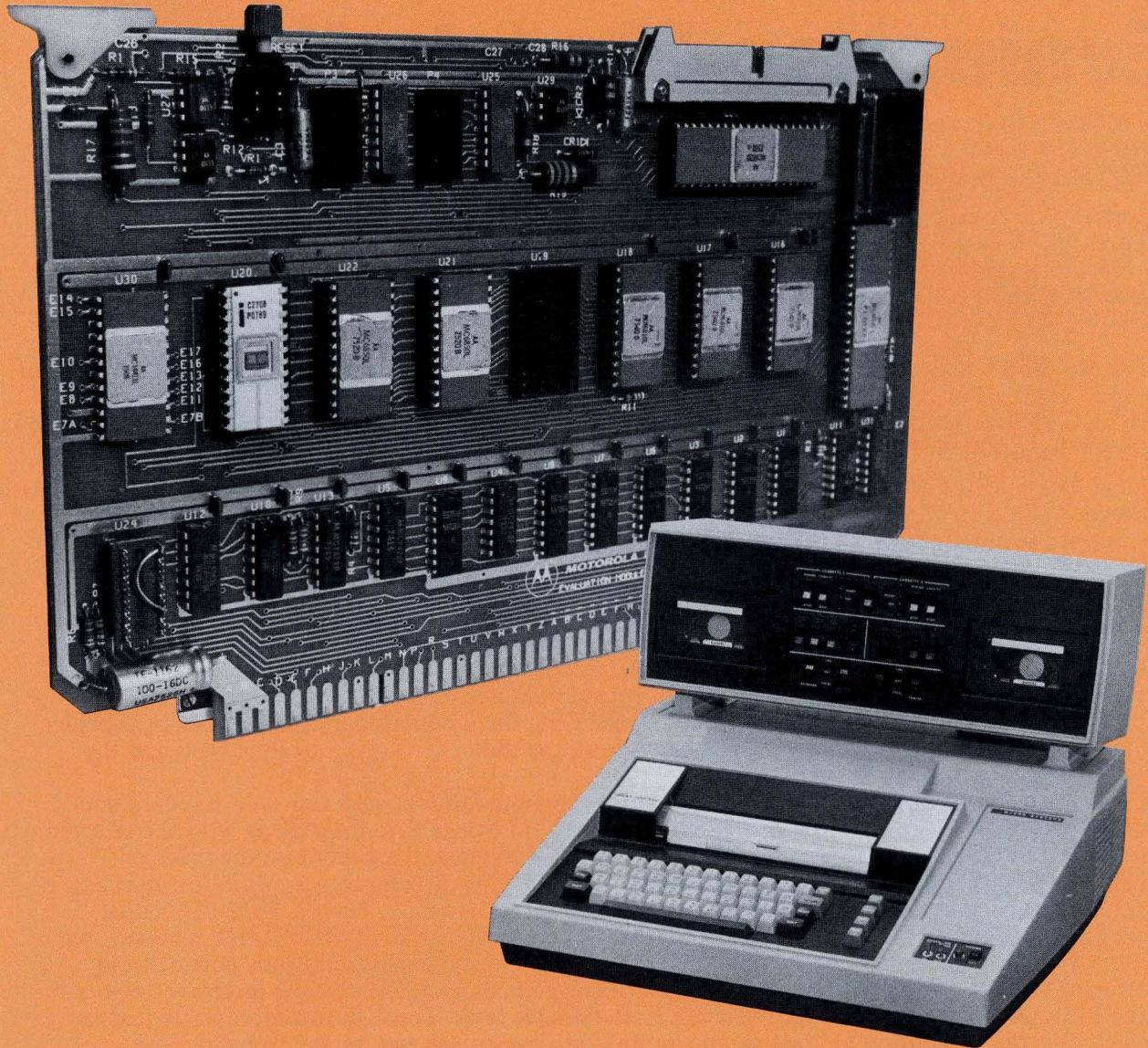

# **M6800B**

## **Evaluation Module II**

### **For Hardware Evaluation and Program Development**

# M6800B

## Evaluation Module II

The M6800B Evaluation Module II is a Microcomputer that provides the user with an efficient and economical off-the-shelf means to evaluate the operating characteristics of the M6800 Microcomputer family of parts in various applications. It contains the following components:

- One M6800 Microprocessing Unit (MPU)
- Three MCM6810 128 x 8 Random Access Memories (RAM)
- One MCM6820 Peripheral Interface Adapter (PIA)
- One MCM6830 1024 x 8 Read Only Memory (ROM)
- Two MC6850 Asynchronous Communications Interface Adapters (ACIA)
- One MC14411 Bit Rate Generator (BRG)
- Data and address buffers

The M6800B Evaluation Module II interfaces with either a TTY (20 mA neutral current loop) or an RS-232C compatible terminal. This data terminal provides direct communication with the module's MINIBUG control program. The MINIBUG control program, stored in the module's read only memory, in conjunction with the selected data terminal, provides the following functions:

- Load data into the Evaluation Module
- Display and, if required, change the data in the module's random access memory
- Display and, if required, change the contents of the MPU registers
- Print out or punch (record) on tape the data stored in the module's memory
- Set the number of stop bits for data communication
- Run the user's program

The Evaluation Module provides the user with 256 bytes of random access memory on which to develop his programs. In addition, this module, through its address and data buffers, is capable of interfacing with additional memory and input/output modules.

The module's clock circuitry, in addition to generating the module's basic timing signals, provides the Evaluation Module with dynamic memory refresh capability on a cycle stealing basis and the ability to work with slow memories.

The MC14411 Bit Rate Generator provides the Evaluation Module with fourteen standard baud rates — six of which are jumper selectable. The MINIBUG II Firmware, in interfacing with the selected data terminal, is capable of transferring data at either 110 or 300 baud, dependent on the terminal.

The Evaluation Module also has the capability of connecting directly to a user's defined process or peripheral device through its MC6820 PIA and second MC6850 ACIA. The MC6820 PIA's dual input/output ports and control lines permit interfacing the Evaluation Module with keyboards, basic printers, displays, and similar devices. The MC6850 ACIA's serial communications port permits interfacing the Evaluation Module with modems, data terminals, and similar serial interface devices at one of the Bit Rate Generator's jumper selectable data transfer rates. Through the appropriate jumper connections, the Evaluation Module can be modified to operate at any one of 14 baud rates.

## Options

Option	Part Number	Description
1	MEC6800B	Assembled and Tested Evaluation Module Assembly
2	MEC6800B1	Bareboard — Printed Circuit Board only. User supplies components.

Parts supplied with the MEC6800B — Three 16-pin component boards.  
PIA Connector and Flatribbon Cable.  
M6900B Evaluation Module II User's Guide.

# M6800B Evaluation Module II

## Specifications

Power Requirements	+5 Vdc @ 2 A +12 Vdc @ 50 mA -12 Vdc @ 50 mA
Clock Frequency	921.6 kHz
Signal Characteristics	
Connector P1	
Address Bus	Three-State TTL Voltage Compatible
Logic "0"	0.5 V max at 40 mA through a resistor to V <sub>CC</sub>
Logic "1"	2.6 V min at -10 mA through a resistor to ground
Output Off-State Leakage Current	100 $\mu$ A max at 2.6 V
Data Bus	TTL Voltage Compatible
Input Logic "0"	0.0-0.85 V (-200 $\mu$ A max at 0.4 V)
Input Logic "1"	2.0-5.25 V (25 $\mu$ A max at 5.25 V)
Output Logic "0"	0.5 V max at 40 mA through a resistor to V <sub>CC</sub>
Output Logic "1"	2.6 V min at -10 mA through a resistor to ground
Control Bus	
Input Logic "0"	TTL Voltage Compatible
Input Logic "1"	TTL Voltage Compatible
Output Logic "0"	0.5 V max at 40 mA through a resistor to V <sub>CC</sub>
Output Logic "1"	2.6 V min at -10 mA through a resistor to ground
Connector P2, PIA Signals	
Data Signals	
PA0-PA7 Input/Output Lines	TTL Voltage Compatible
PB0-PB7 Input/Output Lines	Three-State TTL Voltage Compatible
Control Lines	
CA1, CA2, and CB1	TTL Voltage Compatible
CB2	Three-State TTL Voltage Compatible
Connector P3, Terminal Interface Signals	
Data Transfer Rate	110 or 300 Baud
Data Signal Characteristics	TTY (20 mA neutral current loop) or EIA RS-232C compatible
Reader Control Signal	Control signal for manual TTY devices modified for external control
Connector P4, Terminal Interface Signals	
Data Transfer Rate	110, 134.5, 300, 600, 1200 and 2400 Baud (with jumper modifications 75, 150, 200, 1800, 3600, 4800, 7200 and 9600).
Data Signals	EIA RS-232C compatible

## Connections and Descriptions

### Connector P1 — Data, Address, and Control Bus

Signal Mnemonic	Signal Name and Description
<u>IRQ</u>	<u>Interrupt Request</u> — This input signal requests that an interrupt sequence be generated within the MPU. The processor will wait until it completes the instruction that is being executed before it recognizes the request. Then, if the interrupt mask bit in the condition code register is not set (interrupt not masked), the MPU will begin an interrupt sequence. The MPU will respond to the interrupt request by setting the interrupt mask bit high so that no further interrupts may occur.
<u>NMI</u>	<u>Non-Maskable Interrupt</u> — This input signal requests that a non-maskable interrupt sequence be generated within the processor. The processor will complete the instruction that is being executed before it recognizes the <u>NMI</u> signal.
<u>VMA</u>	<u>Valid Memory Address</u> — This output indicates to the memory and peripheral devices that the address on the address bus is valid.
$\phi$ 2	<u>Phase 2 Clock signal</u> — This signal is derived from the memory clock and used to synchronize the transfer of data on the data bus.
<u>MEMCLK</u>	<u>Memory Clock</u> — This is the basic 921.6 kHz clock signal used by the Evaluation Module to generate its $\phi$ 1 and $\phi$ 2 clock signals. A dynamic memory device would use this signal to control its timing.

# Connections and Descriptions

## Connector P1 — Data, Address, and Control Bus (continued)

Signal Mnemonic	Signal Name and Description
TSC	Three-State Control — This input, when high, causes all of the address lines and read/write line to go to their off, or high-impedance, state. The valid memory address, valid user's address, and the bus available signals will be forced low. The data bus is not affected by the three-state control.
BA	Bus Available — This output signal will normally be a low level. When activated, it will go high indicating that the address bus is available. This will occur if the <u>Halt</u> line is low or the MPU is in the WAIT state as the result of executing a WAIT instruction.
MEMRDY	Memory Ready — This signal enables the Evaluation Module to work with slow memories. The Evaluation Module, on receiving a low level Memory Ready input, stops generating the $\phi 1$ and $\phi 2$ clock signals with $\phi 2$ high.
<u>D0-D7</u>	Data Bus — These bi-directional lines, when enabled, transfer data between the MPU and any external modules.
<u>A0-A15</u>	Address Bus — This address line, when enabled transfers the MPU program counter output to any external modules.
<u>HALT</u>	<u>Halt</u> — When this input is in the high state, the MPU will fetch the instruction addressed by the program counter and start execution. When low all activity in the MPU will be halted.
<u>RESET</u>	<u>Reset</u> — This line goes low when the RESET switch is actuated and may be used to reset any external devices. The RESET switch, on being actuated, initiates a MC6800 MPU cold-start vectored interrupt routine.
<u>R/W</u>	Read/Write — This MPU output signal indicates to the external modules whether the MPU is in a read (high) or a write (low) state. The normal standby state of this signal is read (high).
<u>REFREQ</u>	Refresh Request — This signal, when present, initiates a memory refresh operation. The Evaluation Module, on receiving this input from an external module, stops generating the $\phi 1$ and $\phi 2$ clock signals with $\phi 1$ high and, through the Refresh Grant command, instructs the dynamic memory modules to refresh their memories.
<u>REFGNT</u>	Refresh Grant — This signal instructs the dynamic memory modules to refresh their memories.
<u>VUA</u>	Valid User's Address — This signal indicates to the memory and peripheral devices that the address on the bus is valid. On Evaluation Module II, VUA is the same signal as VMA.

## Connector P2 — Peripheral Interface Adapter Signals

Evaluation Module II provides the user with the capability of connecting a parallel peripheral device to the module's MC6820 PIA. This PIA has dual 8-bit input/output ports — PA0-PA7 and PB0-PB7 — along with four control lines — CA1, CA2, CB1, and CB2. Refer to the M6800 System Design Data for details on these signals.

## Connector P3 — TTY/RS-232C Terminal Interconnection Signals

TTY IN	Serial Data In — This line accepts the input from a TTY terminal.
TTY OUT	Serial Data Out — This line transfers data to a TTY terminal.
—	Reader Control — This signal provides the control required to operate the paper tape reader on a modified manual TTY data terminal. The terminal now is under MPU control.
—	Serial Data Common — This line provides a return for the Serial Data In and Serial Data Out signals.
—	Reader Common — This line is connected to Evaluation Module II ground and provides a return for the Reader Control signal.
RS-232 IN	RS-232C Input — This line accepts the data input from a terminal.
RS-232 OUT	RS-232 Output — This line transfers data to a terminal.
DCD	Data Carrier Detect — This high impedance TTL input, when high, inhibits and initializes the receiver section of the MC6850 ACIA.
RTS	Request to Send — This line, when used with an RS-232C terminal, informs the terminal that Evaluation Module is ready to receive data.
CTS	Clear To Send — This line is a low level when an RS-232C terminal is connected to Evaluation Module II and informs the terminal to transfer data.

## Connector P4 — Asynchronous Device Signals

Evaluation Module II, through the other MC6850 ACIA device, provides the user with the capability of connecting asynchronous communications devices to the module. The user can interface directly with the module's ACIA or through the module's RS-232C level converters. The RS-232C interconnection signals are described above. Refer to the M6800 System Design Data for details on the ACIA's signals.

# Evaluation Module II

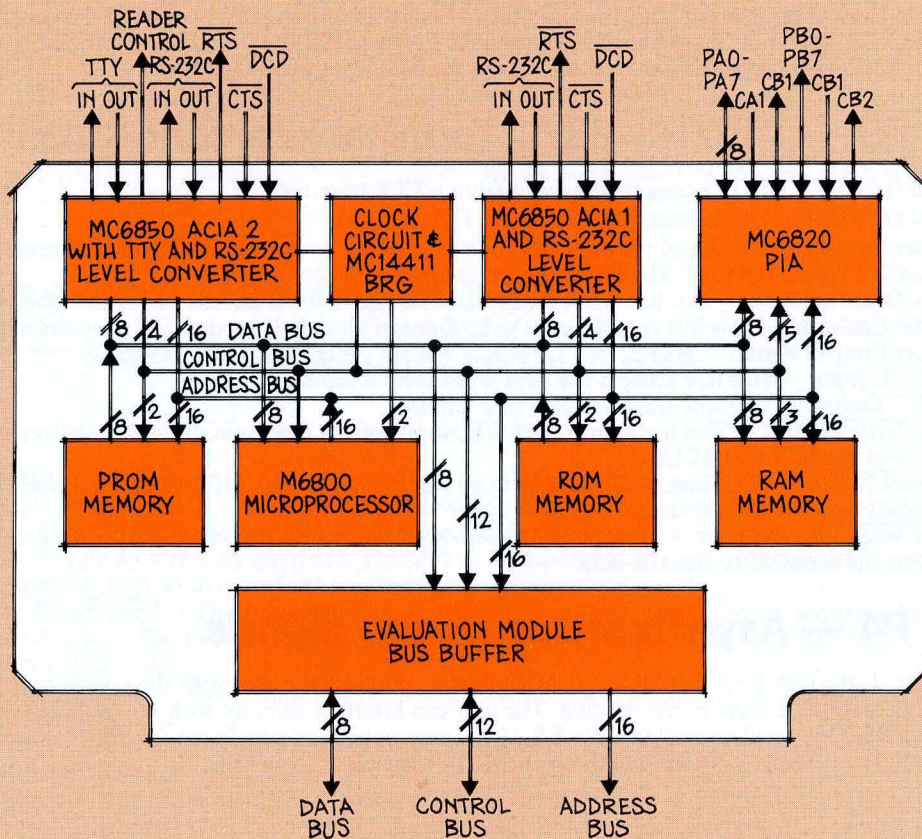
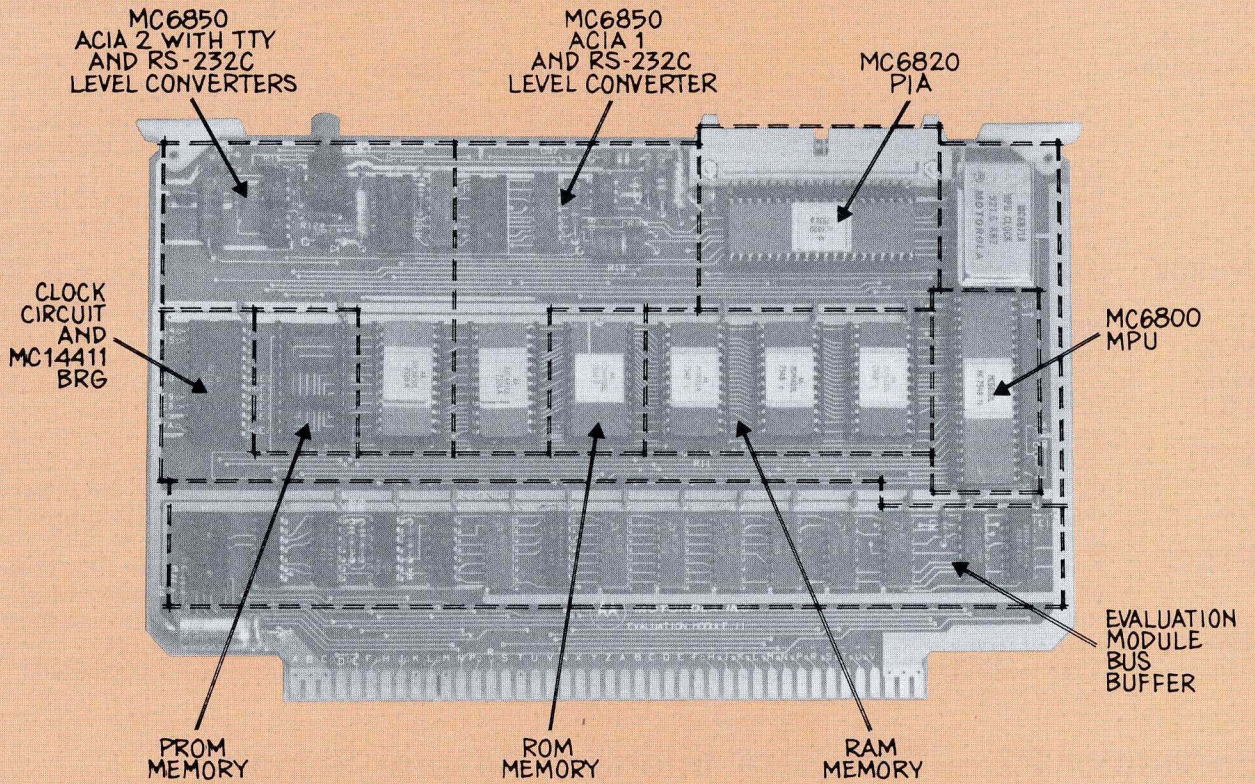



 **MOTOROLA MICROSYSTEMS**

The only peripheral required to use the EXORciser for design purposes is a data terminal. For major design efforts, however, considerable design time can be saved with additional peripherals that speed up program development. EXORdisk and EXORTape are among these development tools.

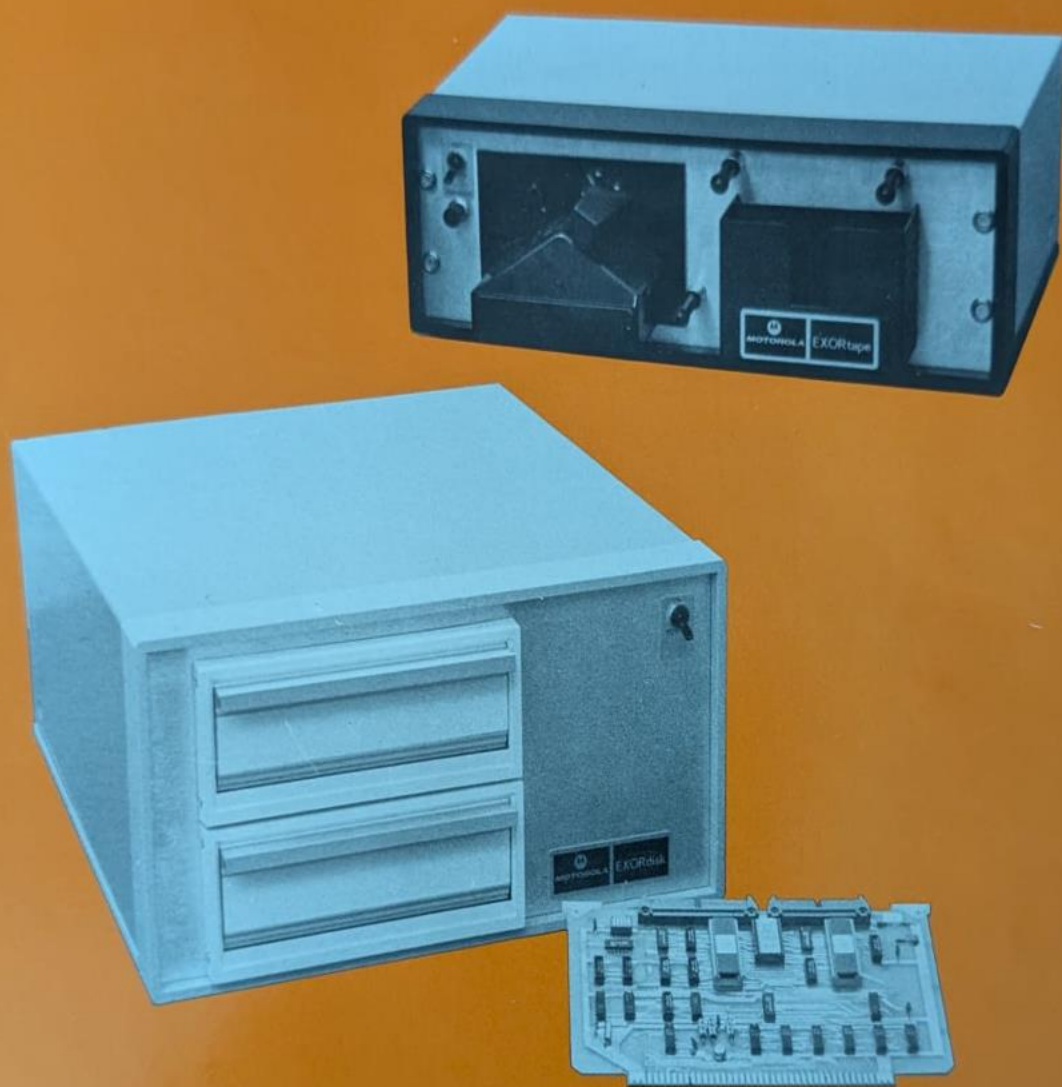

Support Peripherals

# M6800 Support Peripherals



**MOTOROLA MICROSYSTEMS**

# M6800 EXORdisk

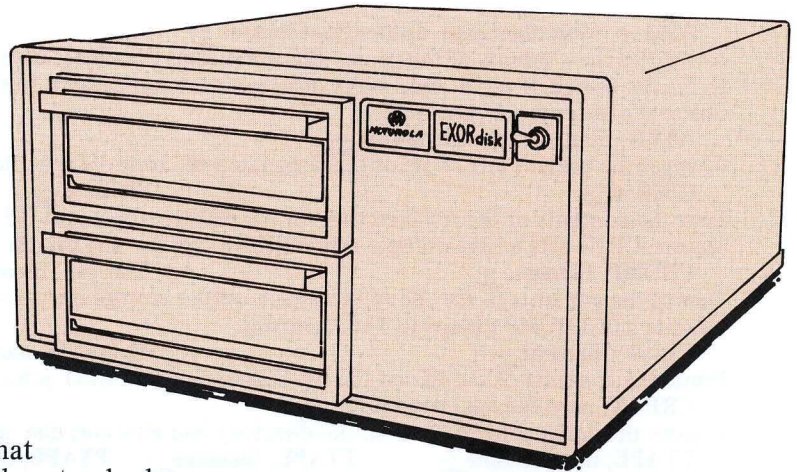

The EXORdisk is a "floppy disk" storage system that extends the EXORciser capacity by up to one-million bytes of memory. Together with the EXORciser, and a separately available Interface Module, it provides a complete program-development system whose high-speed capabilities can be matched only by much more expensive minicomputers. The floppy disk system allows the user to assemble, in 30 seconds, programs that would require up to 2½ hour assembly time with a standard ASR-33 teletype reader.

The EXORdisk system consists of the disk-drive mechanism and a diskette which houses the EXORciser Flexible Disk Operating System II, EDOS II. The latter controls the EXORdisk and interface operations. Functions include the loading of data from the EXORdisk to the EXORciser memory or different diskettes and between diskettes and other storage media such as paper tape and cassette. If desired, the EDOS II program may be purchased on a separate diskette which contains, in addition, the M6800 Resident Editor and Assembler programs. This permits disk-to-disk program editing and assembling in addition to the various transfer functions.

The EXORdisk connects to the EXORciser via an interface module that is an optional component of the EXORciser. This module can be used to simultaneously connect an EXORTape peripheral to the EXORciser.

The EDOS II program will handle and control up to four disk drives, thereby offering memory capacity ranging from 256,256 eight-bit bytes to over 1-million bytes.

## Specifications

### Diskette Format:

2,050,048 Bits/Diskette  
256,256 Bytes/Diskette  
77 Tracks/Diskette  
26 Sectors/Track  
128 Bytes/Sector

### Performance:

Rotational Speed – 360 RPM  
Track-To-Track Access Time – 10 ms  
Head Load – 40 ms  
Sector Read/Write Time – 5 ms  
Average Latency Time – 83 ms  
Interrecord Time – 1 ms  
Head Unload Time Out – 700 ms  
(for maximum head and media life)

Power Requirements: 115/220 Vac, 50/60 Hz, 200 Watts

### Physical Characteristics: (2-drive system)

L x H x D 17 x 8 3/4 x 17 inches  
Weight 65 pounds

### Electrical:

All signals are TTL, Low-True  
16 Output Lines, 8 Input Lines

## Options and Ordering Information

Part Number	Description
M68FD3602	EXORdisk with two drives (includes appropriate two-drive cable)
M68FD3602-12	EXORdisk for 220 V, 50/60 Hz operation
M68FD3602-19	19-inch rack mounting kit
M68FD3602-24	Cable for expanding from two-drive to four-drive system.
M68IFC	M6800 EXORciser Interface Module
M68XAE6812D	Diskette containing EDOS II, M6800 Resident Editor and M6800 Resident Assembler

# EXORdisk Commands

**ASM, p, sourcefilename, destinationfilename** ↷

Assembles the contents of the source file and directs the object to the destination file. If p = 3, only a listing is generated to the list device. If p = 4, only a hex object output is generated to the output object file. If p = 2, both listing and object file outputs are generated.

**ATTR, filename, newattributes** ↷

Changes the present attributes of the designated file to those specified in the new attributes field.

**CDIR: u** ↷

**PDIR: u** ↷

Lists the contents of the file directory on the diskette drive unit 0-3. Lists the filenames, attributes, and file size in sectors. CDIR lists on the console and PDIR lists on the line printer.

**CDUMP, filename** ↷

**TDUMP, filename** ↷

Dumps the contents of the file to the punch output storage device or the communication link device. CDUMP dumps to cassette and TDUMP dumps to TTY terminal.

**CLIST, filename** ↷

**PLIST, filename** ↷

Prints the contents of the file on the list output device. CLIST prints on the console and PLIST prints on the line printer.

**CREAT, newfilename, newfilesize** ↷

Creates the designated filename in the directory and allocates disk space equal to the size.

**CTAPE, newfilename** ↷

**TTAPE, filename** ↷

**PTAPE, filename** ↷

Loads the contents of the reader device into the specified file name on diskette. CTAPE transfers from cassette, PTAPE transfers from a high speed paper tape reader, and TTAPE transfers from a TTY terminal.

**CXGEN** ↷

**PXGEN** ↷

**TXGEN** ↷

Enables system generation of other EDOS versions that may become available in the future.

**DUP** ↷

Copies the contents of the diskette in drive unit 0 onto the diskette in drive unit 1.

**EDIT, inputfilename, newoutputfilename** ↷

**EDIT, newoutputfilename** ↷

Enables editing of the input file's contents. Edited data is stored into the output file.

**EXBUG** ↷

Returns to the EXORciser EXbug control program.

**HOME: u** ↷

Positions the disk head on drive unit u (0-3) to track 0.

**INIT: u** ↷

**INITX** ↷

Initiates the file directory on the diskette in drive unit u. Clears any existing user files on the diskette.

INITX implies drive unit 0 and u in INIT: u designates drive unit 1, 2, or 3.

**LOAD, objectfilename** ↷

Loads the contents of the file into RAM memory for execution.

**MERGE, newfilename, filename1, filename2. . . filename** ↷

Creates a new file which is a concentration of filenames 1-n, in that order.

**PURGE: u, filename1, filename2. . . filename** ↷

Deletes the designated files from the diskette in drive unit u (0-3) and then repacks the contents of that diskette, making disk space available for additional files.

**RENAM, oldfilename, newfilename** ↷

Renames the old file with the new file name.

## Interface Command and Data Words

### all signals are compatible with MC6820 PIA Chips

Input Data and Status: 8 bits, negative true, PIA address  
ECO0, bits 0-7  
Logic 1: 0 to 0.4 volts  
Logic 0: 2.4 volts min

Output Data: 8 bits, negative true, PIA address  
ECO6, bits 0-7.

Output Commands: 8 bits, negative true, PIA address  
ECO2, bits 0-7.

Note: IRQA1 bit 7 is device BUSY.

#### COMMAND FUNCTIONS

**SEEK AND VERIFY:** Seeks Selected Track and Verifies Track Address from ID Field:

**SEEK TRACK 0:** Seeks Track 0

**SECTOR AND UNIT SELECT:** Specifies Sector and Unit Number for Read/Write Operation

**TRACK SELECT:** Specifies Selected Track to be used by Next Seek

**WRITE:** Write Contents of Write Buffer to Selected Sector and Unit on existing track

**READ:** Reads Contents of Selected Sector into Read Buffer  
**WRITE DELETED DATA ADDRESS MARK:** Same as Write but uses header in Data Field which can later be detected in Read Operation

**READ CRC:** Same as Read but no data is transferred to the Read Buffer. Used to verify integrity of data previously written

**SHIFT WRITE BUFFER:** Loads Data into Write Buffer

**SHIFT READ BUFFER:** Inputs Data from Read Buffer

**GATE STATUS:** Gates Status or Data onto Input Data Lines.



**MOTOROLA Semiconductor Products Inc.**

BOX 20912 • PHOENIX, ARIZONA 85036 • A SUBSIDIARY OF MOTOROLA INC.

# M6800 EXORtape

- Plug Compatible with the EXORciser
- Compatible with the EXORciser's EXbug Firmware and Resident Software
- Up to 25 Times Faster Than a Standard ASR-33 Teletype Reader
- Photo Electric Character Detector for More Reliable Loading
- Derated Long Life, Line Filament Type Lamp

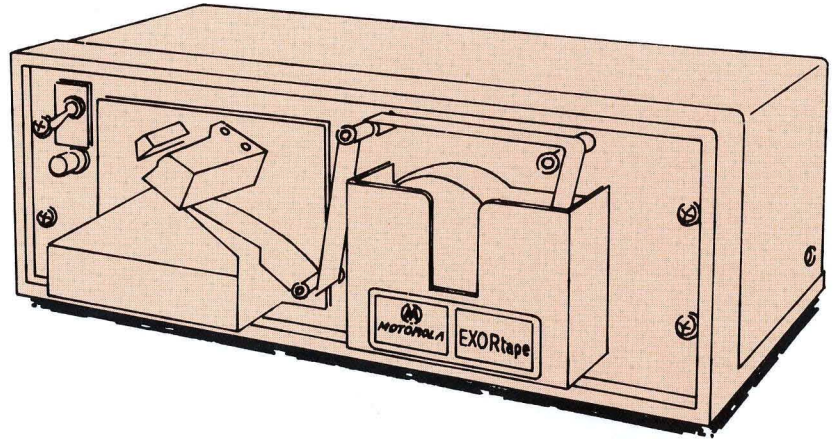

EXORtape is a high-speed paper-tape reader that provides an efficient means for program loading, editing and assembling. It is capable of loading up to 250 characters per second into EXORciser memory. The EXORtape connects to the EXORciser through the optional M6800 EXORciser Interface Module and is completely compatible with the EXORciser EXbug firmware and the M6800 Resident Software. Its Interface program also permits the user to daisy-chain other peripherals, such as the EXORdisk, into the system.

## Specifications

<b>Electrical</b>	
Input Data	8 bits
Status Input	Reader busy
Start Command	HPST start bit
Power Requirements	115 Vac, 60 Hz single phase, 40 W
Optional	220 Vac, 50/60 Hz single phase
Manual Advance	Front panel push button
Speed	Up to 250 characters per second
<b>Physical</b>	
Cables	One 40 line ribbon cable, length 5 feet
<b>Dimensions</b>	
L x H x D	17-1/2 x 6 x 8-1/2"
Mounting	Stand alone, rubber feet, optimal 19 inch RETMA rack mount
Weight	10 pounds
I/O Cabling	Rear/Center
Tape Holder	Up to 5 inches diameter tapes

## Options and Ordering Information

Part Number	Description
M68R680	Table Top EXORtape
M68R680-12	EXORtape with 220, 50/60 Hz Power Requirement
M68R680-19	19-inch Rack Mounting EXORtape
M68IFC	M6800 EXORciser Interface Module



## MOTOROLA MICROSYSTEMS

The use of microprocessors can greatly simplify many hardware designs. However, a microprocessor-based design includes software, an element not found in conventional hard-wired designs. The proper tools are essential to the design of a microprocessor system.

Although microprocessor software can be written directly in machine language, this is too tedious, time-consuming, error-prone, and expensive for all but the smallest system.

Most microprocessor software is presently written in assembly language. At this level, the programmer has complete and explicit control of the microprocessor, while the assembler relieves him of many burdensome details. High-level languages (compilers) are becoming increasingly popular for programming microprocessors. Although such programs are typically somewhat larger and slower than those written in assembly language, they can be developed more rapidly and maintained more easily.

Motorola provides software development tools for three environments:

1. Resident Software – Use of the EXORciser for software development permits dual use of this system development equipment. This low-cost alternative for software development employs the same prototyping hardware used for program test and hardware/software integration. Software development tools also are available for Motorola's Evaluation Modules.
2. In-House Computer Systems – Cross-computer software provides low-cost program development and simulation facilities for in-house computer systems ranging from minicomputers to large mainframe machines. Capabilities of an in-house system may include powerful system software, high-speed peripherals, and multiple-user access.
3. Time-Sharing – The user has immediate worldwide access to M6800 software development packages. Time-sharing provides access to a powerful user-oriented system at a minimal initial cost. It may also be used in meeting workload peaks and critical schedules.



# M6800 Support Software



# M6800 Resident Software



The M6800 Resident Software consists of an Editor and Assemblers designed to operate in conjunction with the EXORciser's EXbug Firmware and the MIKBUG and MINIBUG Firmware of the Evaluation Module. Together, this Software/Firmware combination facilitates the development of software in real time with the actual peripheral devices incorporated in the development system.

This means that the final system software can be prepared, assembled and debugged in its actual working environment. Specifically, the Editor and Assembler routines of the Resident Software can be used to prepare and assemble the system software, while the EXbug, MIKBUG or MINIBUG Firmware is used to debug the software as well as the system hardware.

The M6800 Co-Resident Editor and Assembler can co-reside in an 8K byte read-write memory. The Co-Resident Software and the Macro Assembler/Linking Loader are available in several media – cassette, paper tape, and diskette.

## The Co-Resident Editor

The Co-Resident Editor consists of a number of program routines that are useful in creating or modifying alphanumeric text. In particular, it facilitates the creation, correction and modification of M6800 source programs.

## The Co-Resident Assembler

The M6800 Co-Resident Assembler may be used with the EXORciser and Evaluation Module to translate M6800 Source Programs to machine language.

## The Resident Macro Assembler and Linking Loader

This software provides more powerful development capability for the EXORciser. Included are relocation, linking, macros, conditional assembly, and combination of relocatable object modules to produce an absolute object image.

## Resident FORTRAN Compiler

The Resident FORTRAN Compiler provides the EXORciser with a high-level program development capability. This Compiler is a subset of the ANSI standard for FORTRAN IV.



**MOTOROLA**  
**Semiconductors**

## M6800 RESIDENT SOFTWARE

### Advance Information

#### M6800 RESIDENT SOFTWARE

The optional M6800 Resident Software, along with the M6800 EXORciser's EXbug Firmware, allows the EXORciser user to develop his system software in real-time with his peripheral devices incorporated into the system. This means that the user can prepare, assemble, and debug his system software in its actual working environment. The M6800 Resident Editor and Assembler are used to prepare and assemble the user's system software, while the EXORciser's EXbug Firmware is used to debug the system hardware as well as the software.

#### EXORciser RESIDENT EDITOR and RESIDENT ASSEMBLER

EXORciser



#### M6800 RESIDENT EDITOR

The M6800 Resident Editor may be used to create or modify alphanumeric text. In particular, the Editor gives the user an easy means to create and modify source programs for input into the M6800 Resident Assembler. This interactive Editor offers character, line, and character string commands.

- Memory Sizing Capability
- Insert or Delete Lines
- Insert, Delete or Modify Character Strings
- Command Chaining
- Co-Resident with the M6800 Assembler or Stand Alone

#### M6800 RESIDENT ASSEMBLER

The M6800 Resident Assembler may be used with the M6800 EXORciser to translate M6800 Source Programs to machine language. This assembler is a two-pass assembler; that is, the Resident Assembler reads a user's program twice — once to build a symbol table and a second time to produce the assembled output. Only pass two of the assembler is needed with programs having no forward references and with short programs. In the case of short programs, the forward references will be flagged with an error and the user is required to patch in the correct addresses after the symbol table is printed at the completion of the assembly. The Resident Assembler is compatible with the Cross Assemblers available from Motorola.

- Two-Pass Assembler
- Limited One-Pass Capability
- Can Be Co-Resident with the M6800 Resident Editor or Stand Alone
- Compatible with Motorola's Cross Assemblers

#### EXbug FIRMWARE

The EXbug Firmware is an integral part of the M6800 EXORciser. This firmware allows the user to load the M6800 Resident Assembler and Editor into the EXORciser and to verify that the Resident Software was correctly loaded, and to debug the user's system hardware and software. Also, this Firmware is used to print and/or punch the data stored in the EXORciser memory.

#### RESIDENT SOFTWARE REQUIREMENTS

- EXORciser
- 8K bytes of RAM minimum
- TTY (20 mA neutral loop current) or RS-232C data terminal with automatic reader/punch control

#### ORDERING INFORMATION

The user has the option of ordering the Resident Software in a stand-alone package or ordering the software with 8K bytes of memory. The user can also select the media on which he wishes to receive his Resident Software. Table 1 shows the complete range of options, and the Part Number to be used when ordering.

TABLE 1 -- M6800 RESIDENT SOFTWARE OPTIONS

Option	Description	Media	Part Number
1	Resident Assembler/Editor (Stand Alone)	Cassette	M68XAE6812A0
2	Resident Assembler/Editor with four 2K Static RAM Modules	Cassette	M68XAE6812A2
3	Resident Assembler/Editor with one 8K Dynamic RAM Module	Cassette	M68XAE6812A8
4	Resident Assembler/Editor (Stand Alone)	Paper Tape	M68XAE6812B0
5	Resident Assembler/Editor with four 2K Static RAM Modules	Paper Tape	M68XAE6812B2
6	Resident Assembler/Editor with one 8K Dynamic RAM Module	Paper Tape	M68XAE6812B8
7	Resident Assembler/Editor (Stand Alone)	G.E. Timeshare	M68XAE6812C0
8	Resident Assembler/Editor with four 2K Static RAM Modules	G.E. Timeshare	M68XAE6812C2
9	Resident Assembler/Editor with one 8K Dynamic RAM Module	G.E. Timeshare	M68XAE6812C8
10	Resident Assembler/Editor (Stand Alone)	Floppy Disk	M68XAE6812D0
11	Resident Assembler/Editor with four 2K Static RAM Modules	Floppy Disk	M68XAE6812D2
12	Resident Assembler/Editor with one 8K Dynamic RAM Module	Floppy Disk	M68XAE6812D8

**MOTOROLA Semiconductor Products Inc.**

Printed in Switzerland



**MOTOROLA**  
**Semiconductors**

BOX 20912, PHOENIX, ARIZONA 85036

## Advance Information

### M6800 RESIDENT MACRO ASSEMBLER AND LINKAGE EDITOR

The Resident Macro Assembler and Linkage Editor provide powerful new software development capabilities for the EXORciser. The Macro Assembler provides a superset of the standard resident assembler features, including relocation, linking, macros, and conditional assembly. The Linkage Editor combines relocatable object modules to produce an absolute object image. Object images may be created either in memory or on an external storage medium. Operation of the Macro Assembler and Linkage Editor are shown in the diagram.

#### RELOCATION

Relocation allows the assignment of absolute memory addresses to a program at linkage edit time rather than at assembly time. Programs assembled by the Macro Assembler can be loaded anywhere in memory by the Linkage Editor.

#### LINKING

Linking allows intermodule references to be resolved at linkage edit time rather than requiring absolute address assignment at assembly time. As relocatable programs are loaded by the Linkage Editor, labels are assigned absolute addresses, and references to such labels in other program modules can be satisfied.

#### MACROS

Macros are used to assign a name to a "template" sequence of assembly-language instructions. Subsequent use of the macro name causes that instruction sequence to be inserted into the assembler input stream. Arguments supplied with a macro call are inserted into specified locations in the template.

#### CONDITIONAL ASSEMBLY

Conditional assembly may be used to select or omit optional source statements for assembly.

#### MACRO ASSEMBLER FEATURES

Upward compatible with standard Resident Assembler with the following enhancements:

##### Output

- Absolute object — EXORciser loadable format
- Relocatable object — Linkage Editor loadable (object module)
- Memory load

##### Program Sections

- Absolute — non-relocatable
- Base — directly addressable (0-255)
- Blank Common — uninitialized common
- Data — data section (external addressing)
- Program — instruction section
- Named Common — common sections included within one of the above

(Continued)

## M68ASMRO20

### M6800 SOFTWARE

#### SOFTWARE OPTIONS

Option	Media	Part Number
A	Cassette	M68ASMRO20A
B	Paper Tape	M68ASMRO20B
D	Floppy Disk	M68ASMRO20D

#### OPERATION OF MACRO ASSEMBLER LINKAGE EDITOR

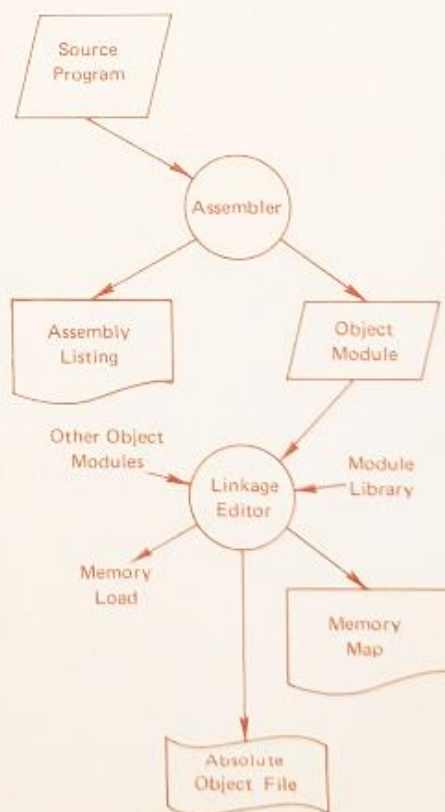

**Linking**

- External definitions
- External references

**Macros**

- Up to 36 arguments
- Strict character substitution for arguments
- Assembler generated symbols
- Up to 8 levels of nesting
- Repeat Macro capability

**Conditional Assembly**

- String/expression tests
- Up to 8 levels of nesting

**Other**

- Symbol cross reference table
- Listing line width control
- Title on each page of listing
- SET — symbol redefinition
- BSZ — block storage — initially zero
- Expression evaluation — parenthesized expressions

**LINKAGE EDITOR FEATURES**

- Relocation of object modules
- Linking of object modules
- Two output modes
  - Direct memory load
  - Binary memory image (EXORciser load format)
- Memory load map
- Map of external symbols
- Undefined symbol list
- Flexible I/O device assignment
  - Disk
  - Console
  - Tape
  - Line printer
- Overlays



# M68BASR010 Resident BASIC Interpreter

The EXORciser-resident BASIC interpreter provides a new tool for problem solving to the M6800 Microcomputer family of parts. BASIC is a high-level programming language widely used for general purpose and certain business-related applications.

- Decimal arithmetic
- String variables and arrays
- Direct statement execution for Debug (calculator mode)
- Only 8K bytes of memory required for small programs
- Call machine language programs
- BASIC may reside on cassette, paper tape, or diskette
- User programs may reside on cassette, paper tape, or diskette
- Program output to printer or console
- Optional LET statement
- String functions and concatenation

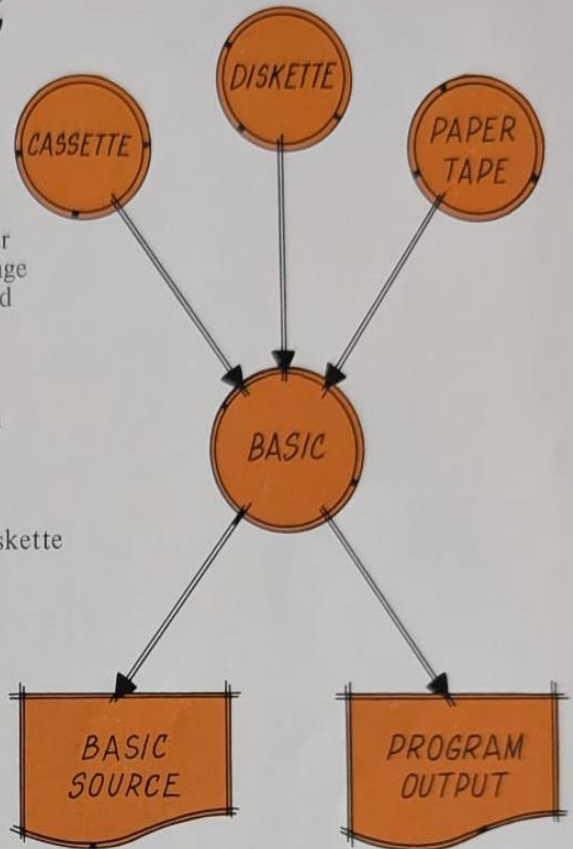

## System Configuration

The minimum system hardware configuration is:

- An EXORciser
- 8K bytes of memory
- An EXORciser compatible terminal

The minimum configuration may be expanded up to 65,536 bytes of memory and up to four disk drives providing over a million bytes of disk storage.

## Language Features

### Data Types

- Range (1.0E - 99 to 9.99999999E + 99) may be represented as either integer, decimal, or exponential.

### Variable Names

- Single alphabetic character or single alphabetic character followed by a digit (0 through 9).
- String variables, single alphabetic character followed by a \$.

### Arithmetic and Logical Operators

- Exponential
- Negate
- Multiplication
- Division
- Addition
- Subtraction
- Relational operators

### Sequence Control Statements

- GOTO
- ON expression GOTO statement n, (m, . . . , 1)
- ON expression GOSUB statement n, (m, . . . , 1)
- IF relative
- FOR
- NEXT
- STOP
- END

### I/O Statements

- INPUT
- READ
- DATA
- PRINT
- RESTORE

### Specification Statements

- DIM - dimension variables and strings

### Remark Statements

- REM

### Optional Statements

- LET

# BASIC Commands

- LIST – display source
- RUN – execute program
- CONT – continue after stop or break
- NEW – define new program
- SAVE – save current program (tape or diskette only)
- LOAD – load new program (tape only)
- APPEND – add to program from tape (tape only)
- PATCH – patch memory from MAID
- TRACE ON – prints line number as it is executed
- TRACE OFF – turns off trace
- LINE LENGTH – define maximum print line length
- DIGITS – establishes the number of digits to right of decimal point
- POKE – sets absolute memory address

## Subprograms

- DEF – define user function
- RETURN – return from subroutine
- GOSUB – go to subroutine

## Intrinsic functions

- TAB – tab on print
- RND – random number
- INT – integer number
- ABS – absolute value
- SGN – sign of argument
- POS – position of printhead
- LEN – number of characters in string
- ASC – decimal value of any ASCII character
- CHR\$ – string value of ASCII character
- STR\$ – ASCII string value to numeric constant
- VAL – numeric constant equivalent to ASCII value
- LEFT\$ – returns left-most string of characters
- RIGHT\$ – returns right-most string of characters
- MID\$ – returns middle string of characters
- PEEK – returns decimal memory value
- SIN – sine
- COS – cosine
- TAN – tangent
- ATAN – arc tangent
- LOG – natural logarithm
- EXP – inverse of LOG
- SQR – square root

## ORDERING INFORMATION

Option	Media	Part Number
1	Cassette	M68BASR010A
2	Paper Tape	M68BASR010B
3	Floppy Disk (EDOS)	M68BASR010D
4	Floppy Disk (MDOS)	M68BASR010M



**MOTOROLA Semiconductor Products Inc.**

BOX 20912 • PHOENIX, ARIZONA 85036 • A SUBSIDIARY OF MOTOROLA INC.

1021-9 PRINTED IN USA 1-77 IMPRESA, LITHO IN MEXICO

# M68FTNR010D Resident FORTRAN Compiler

The EXORciser-resident FORTRAN Compiler provides a new dimension to Motorola's support for the M6800 Microcomputer family of parts as a problem solving and development tool. FORTRAN is a high-level programming language widely used for scientific and engineering problem solving, with features also useful for certain business-related applications. The Resident FORTRAN is a subset of the ANSI standard for FORTRAN IV.

- Relocatable object output file compatible with the M6800 Linking Loader.
- Source and error message output to a printer or the terminal.
- FORTRAN library containing mathematical subroutines and run time I/O routines.
- Optional listing of generated machine language.
- Free field source input.
- Statement continuation.

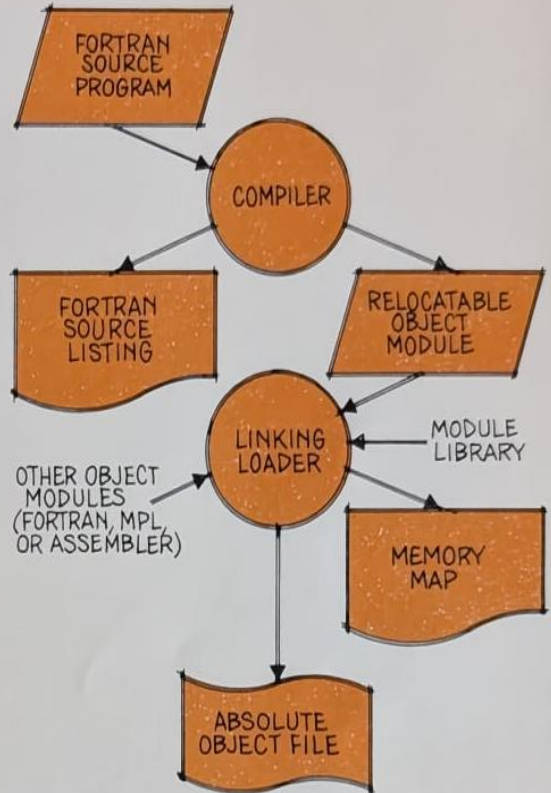

## System Configuration

The minimum system hardware configuration is:

- An EXORciser
- 16K bytes of memory
- An EXORDisk (requires one floppy disk driver)
- An EXORciser-compatible terminal

The minimum configuration may be expanded up to 65,536 bytes of memory and up to four disk drives providing over a million bytes of disk storage.

## Language Features

### Data Types

- Two byte signed integer, maximum magnitude 32,767.
- Four byte real, magnitude  $10^{-78}$  through  $10^{75}$ .
- Literal, one byte character.

### Variable Names

- One through six alphanumeric characters (first character must be A-Z).
- Implicit type declaration according to first character. I through N integer, A through H, O through Z real.

### Arithmetic and Logical Operators

- Exponential
- Multiplication
- Division
- Addition
- Subtraction
- Relational operators

### Sequence Control Statements

- Unconditional GOTO
- Computed GOTO
- Arithmetic IF
- Logical IF
- DO statement
- CONTINUE
- STOP
- END

### I/O Statements

- Formatted READ from disk or terminal
- Formatted WRITE to disk or terminal
- Formatted PRINT to terminal
- Free format READ
- REWIND
- FORMAT conversions
  - I-conversions
  - E-conversions
  - F-conversions
  - A-conversions
- Literal fields
- Character positioning specifications
- Group specifications

### Specification Statements

- DATA initialization
- DIMENSION, three dimensions maximum
- Blank COMMON

### Subprograms

- FUNCTION
- SUBROUTINE
- RETURN
- CALL

### Intrinsic Functions/Subroutines

- SQRT - square root
- EXP - exponent base e
- SIN - sine
- COS - cosine
- ATAN - arctangent
- ALOG - natural logarithm
- ABS - absolute value
- POWER - computes a power
- OPENF - disk file open
- CLOSEF - disk file close

# M6800 Software for In-House Computers

M6800 Software support also is available for In-House computer systems. Compared with Time-Sharing, the use of In-House computers offers lower costs and access to faster peripherals. Three programs are available for software development and simulation:

- **M68SAM** – Cross Assembler
- **M68MPL** – Compiler
- **M68EML** – Simulator

These programs are available on punched cards or magnetic tape (7 or 9 track) and in a machine-independent format. Since these programs are written in ANSI standard FORTRAN IV, they may be installed with a minimum of effort and are easily adaptable to a variety of computers.



**M68SAM** – Cross Assembler converts the assembly language and symbolic statements into an object program consisting of machine language instructions for the M6800 Microprocessing Unit. The assembler also produces an assembly listing.

**M68MPL** – Compiler converts high-level language programs to M6800 assembly language. M68MPL is also available for Time Sharing systems.

**M68EML** – Simulator duplicates the M6800 Microprocessing Unit functions and accumulates timing information. Depending on the installation, the user can have total interactive control over the Simulator to execute, alter, and re-execute his program.



**MOTOROLA**  
**Semiconductors**

BOX 20912 • PHOENIX, ARIZONA 85036

# M68SAM

## Advance Information

### M6800 CROSS ASSEMBLER

M68SAM is a Cross Assembler used to translate M6800 assembly language source programs into M6800 machine language. M68SAM is compatible with the time-sharing and resident assemblers for the M6800 MPU.

Using a host computer for software development reduces the load on the M6800 development systems and provides access to the host computer's other resources including text editors, file systems, and peripherals.

The M68SAM Package includes:

- FORTRAN Source Program
- Formatted Source Listings and Installation Instructions
- A Copy of the *M6800 Microprocessor Programming Manual*

### M6800 CROSS ASSEMBLER

#### ASSEMBLY LANGUAGE INPUT

- 72 Assembly Language Operation Codes
- 7 Address Modes
- 11 Assembler Directives (Pseudo-operations)

END	End of Program
EQU	Equate Symbol
FCB	Form Constant Byte
FCC	Form Constant Characters
FDB	Form Double Constant Byte
NAM	Name
ORG	Origin
PAGE	Top of Form
RMB	Reserve Memory Byte
Space	Space Lines
OPT	Option
DB8	Display Base Octal
DB10	Display Base Decimal
DB16	Display Base Hexa- decimal (default)
LIST	(default)
NOLIST	

### OPERATION OF THE M6800 CROSS ASSEMBLER

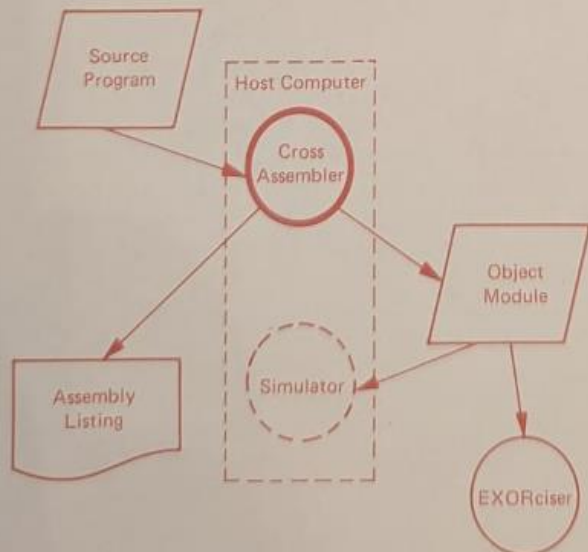

The M6800 Assembly Language is described in the *M6800 Microprocessor Programming Manual*.

#### ASSEMBLER OUTPUT

- Object Program—EXORciser-compatible Format (ASCII Characters)
- Assembly Listing (Display Base Selectable: Octal, Decimal, Hexadecimal)
- Symbol Table

## HOST COMPUTER REQUIREMENTS

- Software
  - FORTRAN IV
  - Any operating system which will support FORTRAN programs
- Memory
  - 16 bit minimum word length (17 bits for 1's complement computers)
  - Memory size requirements vary due to computer and compiler differences. Estimates for common machines are included in Table 1.
- Peripherals
  - M68SAM uses three logical units
    - Source Input
    - Object Output (EXORciser-compatible ASCII format)
    - List Output
  - in general the peripherals needed for FORTRAN are sufficient for M68SAM.

## SOURCE MEDIA

M68SAM consists of approximately 2500 source statements including comments. The source program is available in two forms:

- Cards — 80-Column Punched Cards in O29 Punch Code
- Magnetic Tape — Unlabeled 9-track 800 BPI, Odd Parity, ASCII Character Set, Card-Image Records (80 character/record).

Other media are available on special order.

## INSTALLATION

Although M68SAM was designed to be portable and machine independent, some program functions must be changed to adapt this assembler to the host computer. For computers listed in Table 1, machine dependent modifications already have been incorporated into the program. For these machines, installing M68SAM consists of supplying the job control statements required to run a FORTRAN program.

Installation of M68SAM on other machines is straightforward. Computer dependencies have been isolated and identified as separated program modules. Features which may require minor modification include:

- Input/Output including the assignment of logic devices
- Word-length Parameters
- Intrinsic Function (Logical AND, OR)
- Character Set Translation

The starting point for such an installation should be the Motorola-converted version of M68SAM for the computer closest to the target system. Using the list in Table 1, match the computer characteristics first by the internal character set and then by word size.

TABLE 1— ORDERING INFORMATION

Part Number	Media	Computer	HOST COMPUTER ATTRIBUTES			
			Character Set	Word Size	Negative Number	Memory Used
M68SAM0213E M68SAM0213F	Cards Magnetic Tape	Sigma 9	8-Bit EBCDIC	32 Bits	2's Complement	9K Words
M68SAM0413E M68SAM0413F	Cards Magnetic Tape	HP 2100	8-Bit ASCII	16 Bits	2's Complement	15K Words
M68SAM0713E M68SAM0713F	Cards Magnetic Tape	IBM 360/370	8-Bit EBCDIC	32 Bits	2's Complement	64K Bytes
M68SAM0812E M68SAM0812F	Cards Magnetic Tape	Nova	8-Bit ASCII	16 Bits	2's Complement	16K Words
M68SAM0912E M68SAM0912F	Cards Magnetic Tape	Honeywell 6000	9-Bit ASCII	36 Bits	2's Complement	17K Words
M68SAM1013E M68SAM1013F	Cards Magnetic Tape	CDC 6000	6/12-Bit Display Code	60 Bits	1's Complement	16K Words
M68SAM1113E M68SAM1113F	Cards Magnetic Tape	PDP-11	8-Bit ASCII	16 Bits	2's Complement	16K Words



**MOTOROLA Semiconductor Products Inc.**

BOX 20912 • PHOENIX, ARIZONA 85036 • A SUBSIDIARY OF MOTOROLA INC.



**MOTOROLA**  
**Semiconductors**

BOX 20912 • PHOENIX, ARIZONA 85036

# MPL COMPILER

## Advance Information

### M6800 SOFTWARE . . . MPL COMPILER

MPL is a high-level, user-oriented programming language for the Motorola M6800 Microprocessor. The language is a subset of PL/I with features chosen for applicability to the microprocessor environment.

MPL was designed to simplify the translation from functional requirements for a microprocessor application to operating M6800 programs. The MPL language and its associated compiler provide a powerful software tool which can significantly reduce the time and costs associated with microprocessor software development and maintenance.

- Based on PL/I, a Powerful, High-Level Programming Language Which Is Widely Known and Used
- Supports Free Format, Block Structured Input
- Machine Independent
- Allows Embedded Assembly Language

### M6800 SOFTWARE

### AVAILABILITY

MPL is available worldwide through timesharing. A "portable" version written in ANSI-standard FORTRAN is available for installation on in-house computer systems. Details concerning prices and introduction schedules are available from Motorola Sales Offices.

### MPL ADVANTAGES

- **Easy to Learn**  
The user-orientation of MPL results in reduced training requirements and shorter project start-up times.
- **Easy to Read**  
The self-documenting nature of MPL simplifies software maintenance and product enhancement.
- **Easy to Write**  
User-oriented statement forms and free-format input simplify program writing. The MPL block structure encourages software modularity and structured programming.
- **Easy to Debug**  
A high-level language permits an emphasis on debugging algorithms and design flaws rather than on the details of an assembly language implementation.
- **Easy to Optimize**  
Assembly language output and the use of embedded assembly language allow the optimization of certain program segments for execution speed or memory space, without writing an entire program in assembly language. Calls to assembly language subroutines involve very little overhead.
- **Easy to Upgrade**  
Programs written in MPL for the M6800 will be transferable to future Motorola microprocessor products by recompiling, not rewriting.
- **Easy to Use**
  - Higher productivity for software development
  - Lower software costs
  - Shorter design cycles
  - Easier product modification

### LANGUAGE FEATURES

#### Standard PL/I Statements

PROCEDURE  
DECLARE statement with INITIAL, DEFINED attributes  
IF, THEN, ELSE statement  
DO statement with TO, BY, WHILE clauses  
Assignment statement  
GOTO and GOTO with label arrays  
Subroutine CALL  
RETURN  
END

#### Data Types

Bit string  
Binary (1 or 2 bytes)  
Decimal (signed or unsigned)  
Character  
Labeled arrays

#### Data Classes (Static or BASED)

Multidimensional arrays  
Structures  
Scalars  
Pointers

#### Arithmetic or Logical Operators

Multiplication  
Division  
Subtraction  
Addition  
Shift  
Relational operators  
AND, OR, Exclusive OR

#### Extensions

Address constants  
Computed GOTO  
Embedded assembly language statements  
ORIGIN  
Optional subroutine CALL with register arguments

## HOST COMPUTER REQUIREMENTS

- Software
  - ANSI FORTRAN IV
  - Any operating system that supports ANSI FORTRAN IV.
- Memory
  - 32-bit minimum word length
  - Memory size requirements vary due to computer and compiler differences. Estimates for machines for which the compiler is currently available are given in Table 1.
- Peripherals
  - MPL uses three or five logical units
    - Source Input
    - MPL Subroutine Library Input
    - Compiler Output
    - Terminal Input and Output on a Time-Sharing System
  - In general the peripherals needed for FORTRAN are sufficient for MPL.

## SOURCE MEDIA

MPL consists of approximately 5500 source statements including comments. The source program is available in two forms:

- Cards – 80 Column Punched Cards in O29 Punch Code
- Magnetic Tape – Unlabeled 9-track 800 BPI, Odd Parity, ASCII Character Set, Card-Image Records (80 character/record).

## INSTALLATION

The MPL Compiler has been designed to be as machine-independent as possible. However, some program functions must be changed to adapt it to a particular host computer. For computers listed in Table 1, machine dependent modifications already have been incorporated into the program. For these machines, installing MPL consists of supplying the job control statements required to run a FORTRAN program.

Installation of MPL on other machines is straightforward. Computer dependencies have been isolated and identified as separate program modules. Features which may require minor modification include:

- Input/Output including the assignment of logic devices
- Intrinsic Function (Logical AND, OR; Right and Left Shift)
- Character Set Translation

The starting point for such an installation should be the Motorola-converted version of MPL for the computer closest to the target system. Using the list in Table 1, match the computer characteristics first by the internal character set and then by word size.

TABLE 1 – ORDERING INFORMATION

Part Number	Media	Computer	HOST COMPUTER ATTRIBUTES			
			Character Set	Word Size	Negative Number	Memory Used
M68MPL0210E M68MPL0210F	Cards Magnetic Tape	Xerox Sigma 9	8-Bit EBCDIC	32 Bits	2's Complement	24K Words
M68MPL0710E* M68MPL0710F*	Cards Magnetic Tape	IBM360/370	8-Bit EBCDIC	32 Bits	2's Complement	120K Bytes**
M68MPL0910E M68MPL0910F	Cards Magnetic Tape	Honeywell 6000	9-Bit ASCII	36 Bits	2's Complement	26K Words
M68MPL1010E* M68MPL1010F*	Cards Magnetic Tape	CDC6000	6/12-Bit Display Code	60 Bits	1's Complement	30K Words**

\*Scheduled for availability May 1976.

\*\*Estimate



**MOTOROLA Semiconductor Products Inc.**

BOX 20912 • PHOENIX, ARIZONA 85036 • A SUBSIDIARY OF MOTOROLA INC



**MOTOROLA**  
**Semiconductors**

BOX 20912 • PHOENIX, ARIZONA 85036

# M68EML

## Advance Information

### M6800 SIMULATOR

The M68EML simulates the execution of M6800 machine language instructions in a host computer. Although the simulation is not performed in real time, it maintains a count of the simulated execution cycles. M68EML facilitates the testing and debugging of microprocessor programs in a host computer environment.

The M68EML package includes:

- FORTRAN Source Program
- Formatted Source Listing and Installation Instructions
- A copy of the *M6800 Microprocessor Programming Manual*

### M6800 SIMULATOR

### OPERATION OF THE M6800 SIMULATOR

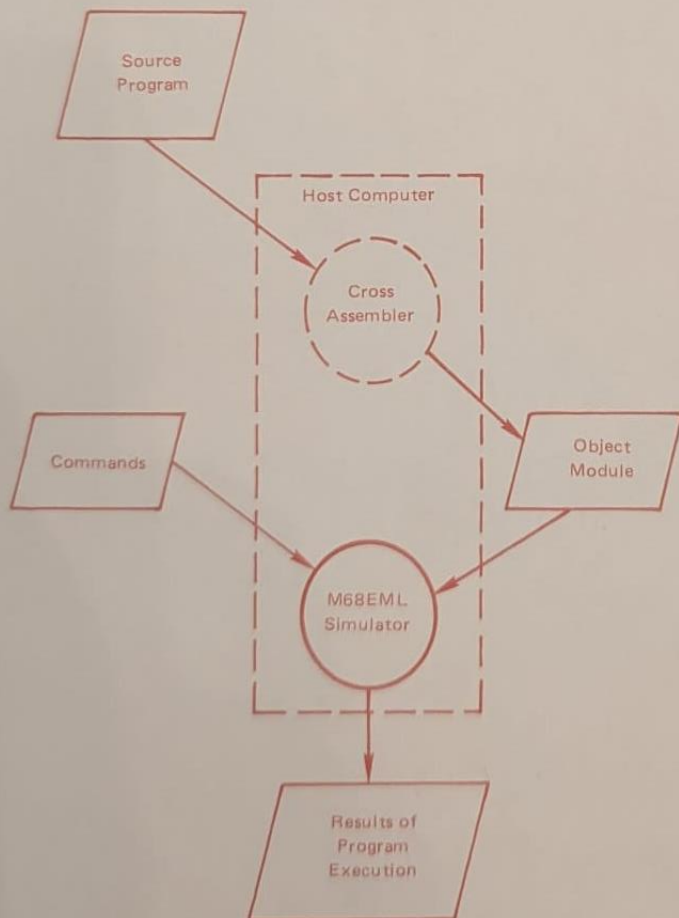

### SIMULATOR INPUTS

- Object File – EXORciser-compatible format (ASCII characters)
- Simulator Commands
  - D – Display Registers
  - DB – Set Display Base
  - DF – Set Display Flag
  - DL – Display Last Instruction
  - DM – Display Memory
  - EX – Exit
  - HR – Set Header Count
  - IB – Set Input Base
  - IM – Input Memory Tape
  - LW – Last Word Address
  - PF – Emulate Non-Maskable Interrupt
  - PO – Emulate Reset
  - R – Run
  - SD – Select Display Registers
  - SM – Set Memory
  - SR – Set Register
  - T – Trace Instruction Execution
  - TB – Trace Branches

A description of these commands is included in the *M6800 Microprocessor Programming Manual*.

### SIMULATOR OUTPUTS

- Trace of Program Execution
  - Instruction Address
  - Operation Code Mnemonic
  - M6800 Registers
  - Effective Address
  - Timing
- Memory Dump
  - Print selected portions of simulated M6800 Memory

**HOST COMPUTER REQUIREMENTS**

- Software
  - FORTRAN IV
  - Any operating system which will support FORTRAN programs
- Memory
  - 16 bit minimum word length (17 bits for 1's complement computers)
  - Memory size requirements vary due to computer and compiler differences. Estimates for common machines are included in Table 1.
- Peripherals
  - M68EML uses three logical units
    - Command Input
    - Object Program Input (EXORciser-compatible ASCII format)
    - List output – Simulation Results
  - In general the peripherals needed for FORTRAN are sufficient for M68EML.

**SOURCE MEDIA**

M68EML consists of approximately 3000 source statements including comments. The source program is available in two forms:

- Cards – 80-Column Punched Cards in O29 Punch Code
- Magnetic Tape – Unlabeled 9-track 800 BPI, Odd Parity, ASCII Character Set, Card-Image Records (80 character/record).

Other media are available on special order.

**INSTALLATION**

Although M68EML was designed to be portable and machine independent, some program functions must be changed to adapt this simulator to the host computer. For computers listed in Table 1, machine dependent modifications already have been incorporated into the program. For these machines, installing M68EML consists of supplying the job control statements required to run a FORTRAN program.

Installation of M68EML on other machines is straightforward. Computer dependencies have been isolated and identified as separate program modules. Features which may require minor modification include:

- Input/Output including the assignment of logic devices
- Word-length Parameters
- Intrinsic Function (Logical AND, OR)
- Character Set Translation

The starting point for such an installation should be the Motorola-converted version of M68EML for the computer closest to the target system. Using the list in Table 1, match the computer characteristics first by the internal character set and then by word size.

**TABLE 1 – ORDERING INFORMATION**

Part Number	Media	Computer	HOST COMPUTER ATTRIBUTES			
			Character Set	Word Size	Negative Number	Memory Used
M68EML0211E M68EML0211F	Cards Magnetic Tape	Sigma 9	8-Bit EBCDIC	32 Bits	2's Complement	17K Words
M68EML0411E M68EML0411F	Cards Magnetic Tape	HP2100	8-Bit ASCII	16 Bits	2's Complement	16K Words
M68EML0711E M68EML0711F	Cards Magnetic Tape	IBM360/370	8-Bit EBCDIC	32 Bits	2's Complement	120K Bytes
M68EML0811E M68EML0811F	Cards Magnetic Tape	Nova	8-Bit ASCII	16 Bits	2's Complement	18K Words
M68EML0911E M68EML0911F	Cards Magnetic Tape	Honeywell 6000	9-Bit ASCII	36 Bits	2's Complement	26K Words
M68EML1011E M68EML1011F	Cards Magnetic Tape	CDC6000	6/12-Bit Display Code	60 Bits	1's Complement	19K Words
M68EML1111E M68EML1111F	Cards Magnetic Tape	PDP-11	8-Bit ASCII	16 Bits	2's Complement	18K Words





# M6800 Time Sharing Systems Software

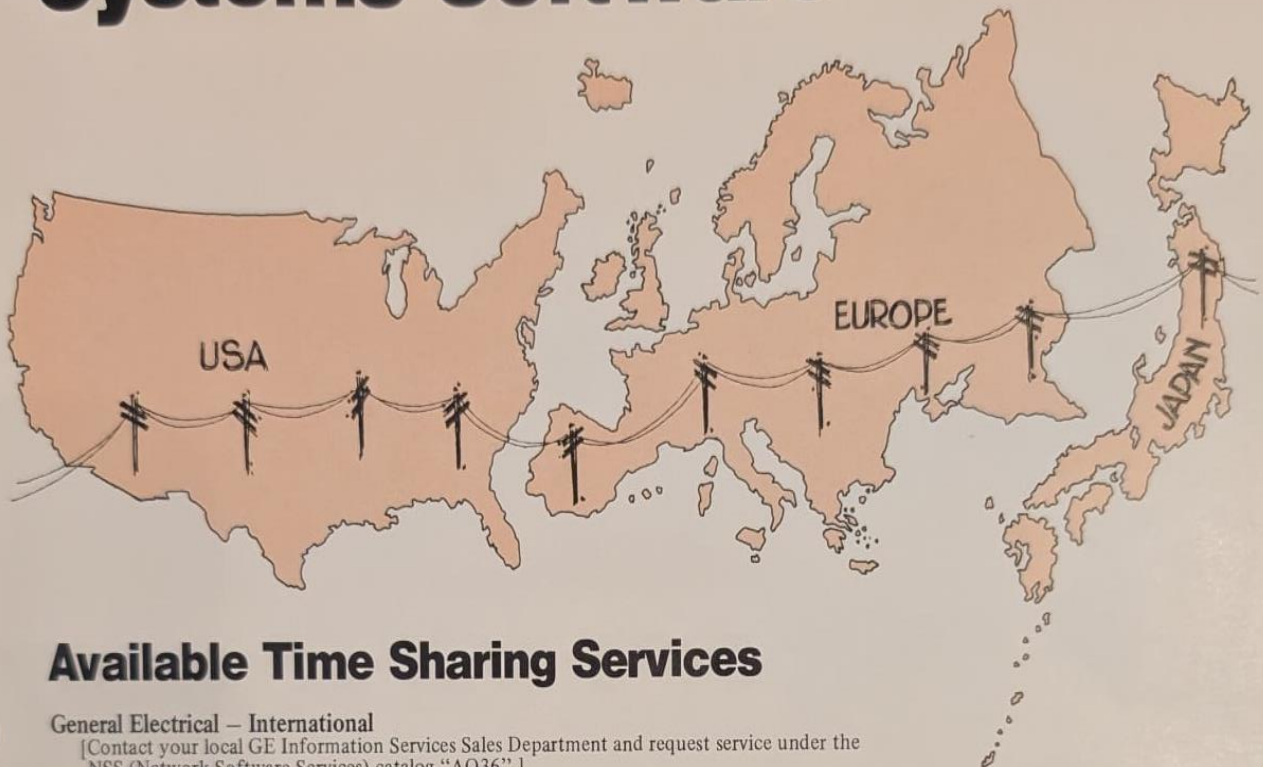

## Available Time Sharing Services

### General Electrical – International

[Contact your local GE Information Services Sales Department and request service under the NSS (Network Software Services) catalog "AQ36".]

### Honeywell-Bull – Europe\*

### Dentsu – Japan\*

\*Contact your Motorola Field Sales Representative for information regarding use of these time-sharing services.

### United Computing Systems – U.S.A.

[Contact your local UCS sales representative for service under catalog M437.]

Time Sharing computer systems provide immediate access to powerful, user-oriented file systems. Such systems, in conjunction with Motorola's Cross-Computer Software, represent cost-effective means for evaluation studies, small or one-time system designs, design projects requiring simultaneous computer access by more than one design team and for extending the capabilities of an In-House or Resident system. Background or remote batch provides deferred processing at a substantial cost saving.

Motorola's M6800 Time Sharing Software package includes the following programs:

**MPCASM** – Cross Assembler

**MPBVM** – Build-Virtual Machine

**MPSSIM** – Simulator

**HELP**

**M68MPL** – Compiler

**MPCASM** – Cross Assembler converts the assembly-language source statements into an object program consisting of machine-language instructions for the M6800 MPU. In addition to producing an assembly listing, the Cross Assembler provides a simulator control file.

**MPSSIM** – Interactive Simulator facilitates the checkout and error elimination in programs written for the M6800 by duplicating in a host computer the exact execution of the machine-language instructions in the program. It gives the user complete control over the program under test.

**M68MPL** – Compiler converts high-level language programs to M6800 assembly language. M68MPL is also available for In-House Computers.

**MPBVM** – Build-Virtual Machine permits the structuring of a program that duplicates the configuration of the actual programmable system. This enables the user to ensure that his programs fit the limits of the memory for his system under development.

The Build-Virtual-Machine program also provides merging and/or loading of object tape files into the memory (machine) file and the generation of object tape files for all or a portion of the memory file.

**HELP** is a program and a system of files that provide assistance to the engineer or programmer on the use of the software and the hardware. Also, **HELP** provides up-to-date information on improvements and new developments to the M6800 Microcomputer Family of parts and software.



**MOTOROLA MICROSYSTEMS**

Motorola provides total design support to customers for the development of M6800-based microcomputer systems. This support includes:

- Documentation
- Training
- Application Assistance



# M6800 Design Support

Design Support



## Documentation

The rapidly expanding list of Motorola M6800-based documents currently includes:

### **BASIC PRODUCT BROCHURES – Available Free**

**M6800 MICROCOMPUTER SYSTEM DESIGN DATA** – complete specifications for basic M6800 components and their utilization in general system design.

**M6800 SUPPORT PRODUCTS** – The hardware and software products described herein are being rapidly expanded. Consult your Motorola sales representative or distributor for data sheets of products not yet included in this brochure.

**M6800 SUPPORT SOFTWARE PROGRAM EXAMPLES** – Basic brochures showing examples for creating, assembling, and testing sample programs with the EXORciser and with GE and UCS in-house and time-sharing systems.

**ENGINEERING NOTE 100 – MCM6830L7 MIKBUG/MINIBUG ROM** – A detailed discussion of programs associated with MIKBUG/MINIBUG firmware.

### **TECHNICAL BOOKS**

**M6800 MICROPROCESSOR APPLICATIONS MANUAL** – An in-depth treatment of the M6800 system in a variety of general and specific applications – price \$25.00.

**M6800 MICROPROCESSOR PROGRAMMING MANUAL** – Detailed information leading to the development of effective M6800 programs – price \$10.00.

### **USER'S GUIDES AND MANUALS – Available at Nominal Charge**

**M6800 EXORciser USER'S GUIDE** – Instructions for the installation and applications of the EXORciser. Includes detailed description of system emulation and program evaluation and debug procedures. – Supplied free with EXORciser.

**EXORciser USER'S GUIDE SUPPLEMENTS** – Detailed instructions for using the optional plug-in Modules with the EXORciser. – Supplied free with optional Modules.

**EVALUATION MODULE II USER'S GUIDE** – Instructions for the installation and operation of Evaluation Module II. Includes detailed discussion of programming procedures. – Supplied free with Evaluation Module II.

**SOFTWARE MANUALS** – Detailed descriptions for using the several software options. – Supplied free with the software package.

## Training

Motorola offers a series of microprocessor courses to assist designers in the development of M6800-based microcomputer systems. The basic course is a concentrated 3-day session covering M6800 hardware, software and support products. The final day is devoted to writing, assembling and simulating a program using time sharing. Other courses are one-day sessions devoted to Support Hardware and Programming. The courses are held periodically in Phoenix, Arizona and at various other locations in the U. S.

For specific details, please contact your Motorola Sales Representative or call

Ron Bishop, Telephone (602) 962-2345.

## Applications Assistance

Motorola maintains a staff of professionally qualified applications engineers to assist customers in the development of M6800-based microcomputer systems. Contact with this group can be made through your Motorola Field Sales Representative.



**MOTOROLA Semiconductor Products Inc.**

BOX 20912 • PHOENIX, ARIZONA 85036 • A SUBSIDIARY OF MOTOROLA INC.

50211-9 PRINTED IN USA 11-76 IMPERIAL LETTER SIZES 134