



MOTOROLA
Semiconductors

MEX6812-1

Advance Information

2K STATIC RAM MODULE

The MEX6812-1 2K Static RAM Module, consisting of 16 N-channel MOS memory devices, provides the EXORciser with 2048 x 8 bits of random access memory. This memory is organized into two separate 1024 byte memory arrays. The bus driver/receivers and the base address selection switches interface the 2K Static RAM Module with the EXORciser bus. The address selection switches permit the user to select the base location address for each memory array in 1K byte increments (0000, 1024, 2048, etc.). The RAM/ROM switch for each array provides the user with the option of using each array as a RAM or pseudo ROM (protecting the memory contents by inhibiting the memory write function).

- TTL Voltage Compatible High Impedance Inputs
- Three-State Data Outputs
- 2048 x 8 Bits of Static N-Channel MOS Memory in Two 1024-Byte Arrays
- Switch-Selectable Base Location Address for Each Memory Array
- 500 ns Memory Access Time
- Each Array Switch-Selectable as a RAM or ROM (RAM Protected by Inhibiting Memory Write Function)

EXORciser
2K STATIC RAM
MODULE

EXORciser



2K STATIC RAM MODULE

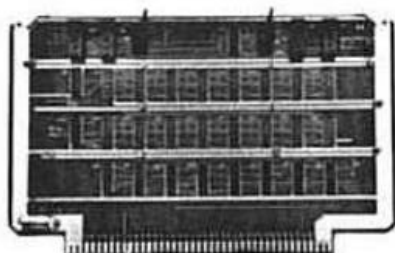

BLOCK DIAGRAM

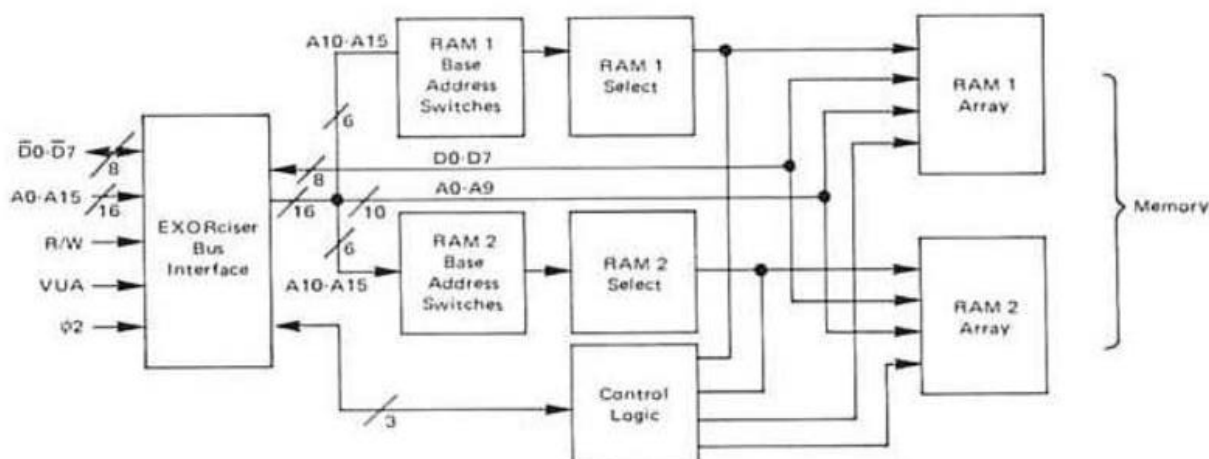

MODULE SPECIFICATIONS

(Note: Positive current flow is defined as flowing into the terminal, negative current flow as flowing from the terminal.)

Specification	Value
Memory Type	N-channel MOS static RAM
Memory Organization	2048 x 8 bits organized into two 1024 x 8 bit arrays
Access Time	500 ns
Input Signals Logic "0" Logic "1"	TTL voltage compatible 0.0-0.85 V (-200 μ A max at 0.4 V) 2.0-5.25 V (25 μ A max at 5.25 V)
Data Bus Input Logic "0" Input Logic "1" Output Logic "0" Output Logic "1" Output Off-State Leakage Current	Three-state TTL voltage compatible 0.0-0.85 V (-200 μ A max at 0.4 V) 2.0-5.25 V (25 μ A max at 5.25 V) 0.5 V max at 40 mA through a resistor to ground 2.6 V min at -10 mA through a resistor to V_{CC} 100 μ A max at 2.6 V
Operating Temperature	0 to 70°C
Power Requirements	5 Vdc at 1 A max
Dimensions Width Height Thickness	9.75 in. 5.75 in. 0.062 in.

EXORciser INTERFACE SIGNALS

The MEX6812-1 2K Static RAM Module interfaces directly with the EXORciser bus using the 8-bit bi-directional data bus, the 16-bit address bus, read/write line, ϕ 2 clock line and valid user's address line. These lines permit the EXORciser to have complete control over the 2K Static RAM Module.

Data Bus ($\bar{D}0-\bar{D}7$) – These eight bi-directional lines, when enabled, provide a two-way transfer of data between the MPU Module and the 2K Static RAM Module. The data bus receivers on the 2K Static RAM Module are continually enabled to receive data. The data bus drivers on this module are in their off or high impedance state except when the module is selected during a memory read operation.

Address Bus (A0-A15) – These 16 lines, when enabled, transfer the selected memory address to the 2K Static

RAM Module. The MPU Module controls the operation of these three-state lines.

Read/Write (R/W) – This MPU Module output signal indicates to the 2K Static RAM Module whether the EXORciser is performing a memory read operation (high) or write operation (low). The normal standby state of this signal is read (high). Also, when the MC6800 MPU on the MPU Module is halted, this signal will be in a read state.

Valid User's Address (VUA) – This signal indicates that the address on the address bus is valid and the EXORciser is not addressing EXbug (upper 4K bytes of memory).

Phase 2 (ϕ 2) Clock Signal – This signal is between 100 kHz and 1 MHz, and is used to synchronize the transfer of data on the data bus. This signal is controlled by the MPU Module.

