

MC6844

DIRECT MEMORY ACCESS CONTROLLER (DMAC)

The MC6844 Direct Memory Access Controller (DMAC) performs the function of transferring data directly between memory and peripheral device controllers. It directly transfers the data by controlling the address and data bus in place of an MPU in a bus organized system.

The bus interface of the MC6844 includes select, read/write, interrupt, transfer request/grant, a data port, and an address port which allow data transfer over an 8-bit bidirectional data bus. The functional configuration of the DMAC is programmed via the data bus. The internal structure provides for control and handling of four individual channels, each of which is separately configured. Programmable control registers provide control for data transfer location and data block length, individual channel control and transfer mode configuration, priority of channel servicing, data chaining, and interrupt control. Status and control lines provide control to peripheral controllers.

The mode of transfer for each channel can be programmed as one of two single-byte transfer modes or a burst transfer mode.

Typical MC6844 applications are a Floppy Disk Controller (FDC) and an Advanced Data Link Controller (ADLC) DMA interface.

MC6844 features include:

- Four DMA Channels, Each Having a 16-Bit Address Register and a 16-Bit Byte Count Register
- 2 M Byte/Sec Maximum Data Transfer Rate
- Selection of Fixed or Rotating Priority Service Control
- Separate Control Bits for Each Channel
- Data Chain Function
- Address Increment or Decrement Update
- Programmable Interrupts and DMA End to Peripheral Controllers

MOS

(N-CHANNEL, SILICON-GATE)

DIRECT MEMORY ACCESS CONTROLLER (DMAC)

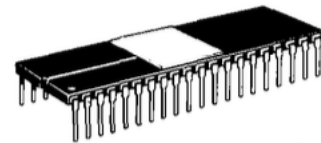

L SUFFIX
CERAMIC PACKAGE
CASE 715

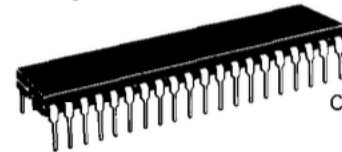

S SUFFIX
CERDIP PACKAGE
CASE 734

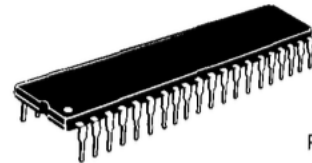

P SUFFIX
PLASTIC PACKAGE
CASE 711

**FIGURE 1 — M6800 MICROCOMPUTER FAMILY
BLOCK DIAGRAM**

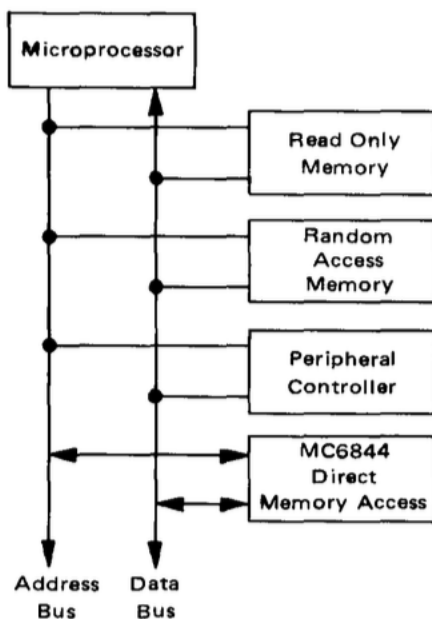

PIN ASSIGNMENT

VSS	1	40	E
\overline{CS}/Tx AKB	2	39	\overline{RESET}
R/ \overline{W}	3	38	\overline{DGRNT}
A0	4	37	$\overline{DRQ1}$
A1	5	36	$\overline{DRQ2}$
A2	6	35	Tx AKA
A3	7	34	Tx STB
A4	8	33	$\overline{IRQ}/\overline{DEND}$
A5	9	32	Tx RQ0
A6	10	31	Tx RQ1
A7	11	30	Tx RQ2
A8	12	29	Tx RQ3
A9	13	28	D0
A10	14	27	D1
A11	15	26	D2
A12	16	25	D3
A13	17	24	D4
A14	18	23	D5
A15	19	22	D6
VCC	20	21	D7

FIGURE 2 — BLOCK DIAGRAM OF DMAC

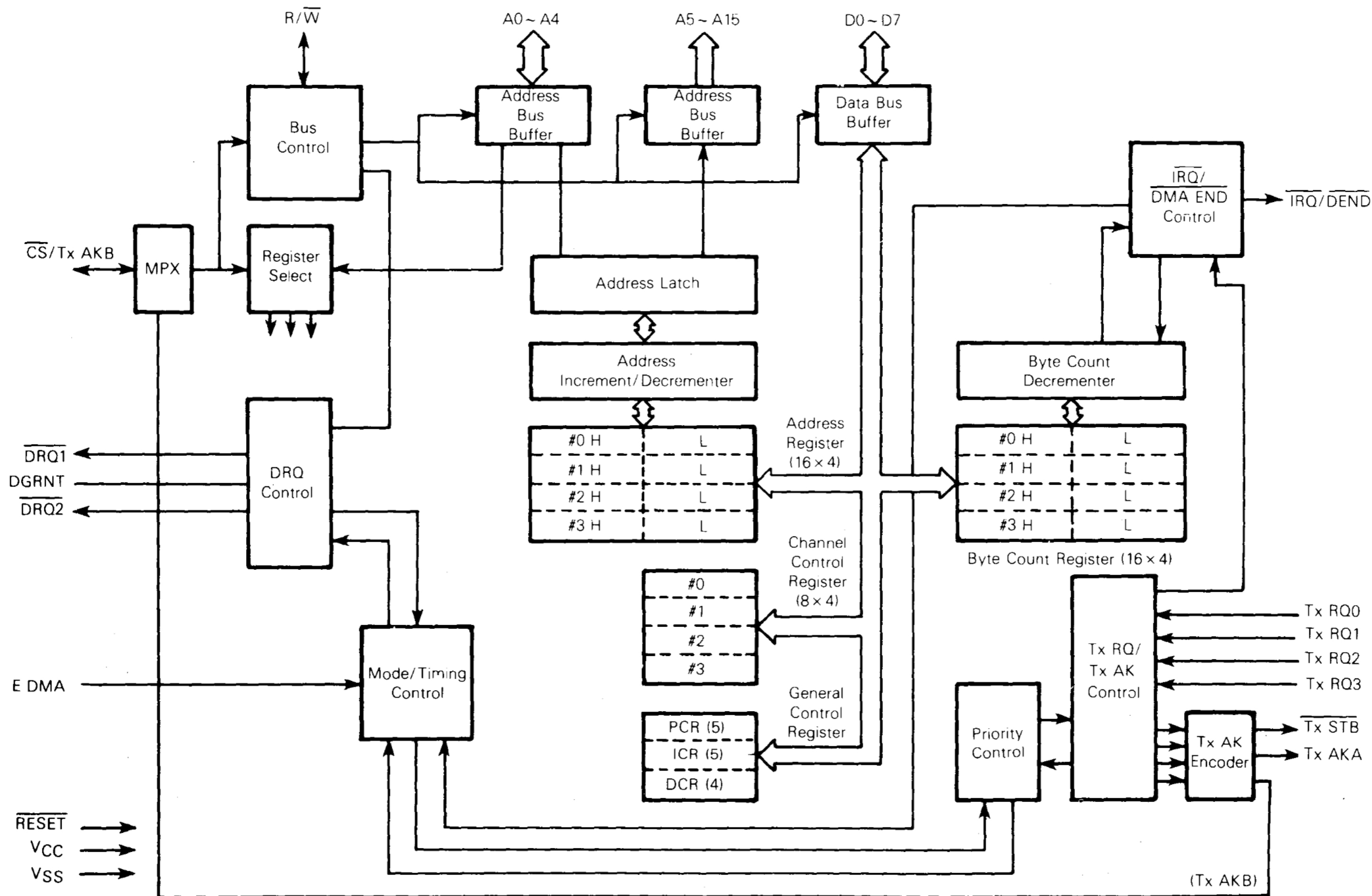

MAXIMUM RATINGS

Rating	Symbol	Value	Unit
Supply Voltage	V_{CC}^*	-0.3 to +7.0	V
Input Voltage	V_{in}^*	-0.3 to +7.0	V
Operating Temperature Range MC6844, MC68A44, MC68B44 MC6844C, MC68A44C	T_A	T_L to T_H 0 to +70 -40 to +85	°C
Storage Temperature Range	T_{stg}	-55 to +150	°C

This device contains circuitry to protect the inputs against damage due to high static voltages or electric fields; however, it is advised that normal precautions be taken to avoid application of any voltage higher than maximum rated voltages to this high-impedance circuit. Reliability of operation is enhanced if unused inputs are tied to an appropriate logic voltage level (e.g., either V_{SS} or V_{CC}).

THERMAL CHARACTERISTICS

Characteristic	Symbol	Value	Unit
Thermal Resistance Plastic Ceramic Cerdip	θ_{JA}	100 50 60	°C/W

POWER CONSIDERATIONS

The average chip-junction temperature, T_J , in °C can be obtained from:

$$T_J = T_A + (P_D \cdot \theta_{JA}) \quad (1)$$

Where:

T_A = Ambient Temperature, °C

θ_{JA} = Package Thermal Resistance, Junction-to-Ambient, °C/W

P_D = $P_{INT} + P_{PORT}$

P_{INT} = $I_{CC} \times V_{CC}$, Watts – Chip Internal Power

P_{PORT} = Port Power Dissipation, Watts – User Determined

For most applications $P_{PORT} \ll P_{INT}$ and can be neglected. P_{PORT} may become significant if the device is configured to drive Darlington bases or sink LED loads.

An approximate relationship between P_D and T_J (if P_{PORT} is neglected) is:

$$P_D = K + (T_J + 273^\circ\text{C}) \quad (2)$$

Solving equations 1 and 2 for K gives:

$$K = P_D \cdot (T_A + 273^\circ\text{C}) + \theta_{JA} \cdot P_D^2 \quad (3)$$

Where K is a constant pertaining to the particular part. K can be determined from equation 3 by measuring P_D (at equilibrium) for a known T_A . Using this value of K the values of P_D and T_J can be obtained by solving equations (1) and (2) iteratively for any value of T_A .

DC ELECTRICAL CHARACTERISTICS ($V_{CC} = 5.0 \text{ Vdc} \pm 5\%$, $V_{SS} = 0$, $T_A = T_L$ to T_H unless otherwise noted)

Characteristic	Symbol	Min	Typ	Max	Unit	
Input High Voltage All Inputs	V_{IH}	$V_{SS} + 2.0$	–	V_{CC}	V	
Input Low Voltage \overline{CS}/Tx AKB Other Inputs	V_{IL}	$V_{SS} - 0.3$ $V_{SS} - 0.3$	–	$V_{SS} + 0.6$ $V_{SS} + 0.8$	V	
Input Leakage Current ($V_{in} = 0$ to 5.25 V)	I_{in}	–	–	2.5	μA	
Hi-Z Leakage Current ($V_{in} = 0.4$ to 2.4 V)	I_{TSI}	-10	–	10	μA	
Output High Voltage $I_{Load} = -205 \mu\text{A}$ $I_{Load} = -145 \mu\text{A}$ $I_{Load} = -100 \mu\text{A}$	V_{OH}	$V_{SS} + 2.4$ $V_{SS} + 2.4$ $V_{SS} + 2.4$	– – –	– – –	V	
Output Low Voltage ($I_{Load} = 1.6 \text{ mA}$)	V_{OL}	–	–	$V_{SS} + 0.4$	V	
Source Current ($V_{in} = 0 \text{ V}$, Figure 10)	I_{CSS}	–	10	16	mA	
Internal Power Dissipation (Measured at $T_A = 0^\circ\text{C}$)	P_{INT}	–	500	750*	mW	
Capacitance ($V_{in} = 0$, $T_A = 25^\circ\text{C}$, $f = 1.0 \text{ MHz}$)	C_{in}	–	–	20	pF	
	C_{out}	D0-D7, CS, A0-A4, R/W	–	–	12.5	pF
		All Others	–	–	10	pF

*For temperatures less than $T_A = 0^\circ\text{C}$, P_{INT} maximum will increase.

MC6844

MPU MODE TIMING (See Notes 1 and 2)

Ident. Number	Characteristic	Symbol	MC6844		MC68A44		MC68B44		Unit
			Min	Max	Min	Max	Min	Max	
1	Cycle Time	t_{cyc}	1.0	10	0.67	10	0.5	10	μs
2	Pulse Width, E Low	PW_{E_L}	430	9500	280	9500	210	9500	ns
3	Pulse Width, E High	PW_{E_H}	450	9500	280	9500	220	9500	ns
4	Clock Rise and Fall Time	t_r, t_f	—	25	—	25	—	20	ns
9	Address Hold Time	t_{AH}	10	—	10	—	10	—	ns
13	Address Setup Time Before E	t_{AS}	80	—	60	—	TBD	—	ns
14	Chip Select Setup Time Before E	t_{CS}	80	—	60	—	40	—	ns
15	Chip Select Hold Time	t_{CH}	10	—	10	—	10	—	ns
18	Read Data Hold Time	t_{DHR}	20	—	20	—	20	—	ns
21	Write Data Hold Time	t_{DHW}	10	—	10	—	10	—	ns
30	Peripheral Output Data Delay Time	t_{DDR}	—	290	—	180	TBD	—	ns
31	Peripheral Input Data Setup Time	t_{DSW}	165	—	80	—	60	—	ns

FIGURE 3 — MPU MODE TIMING

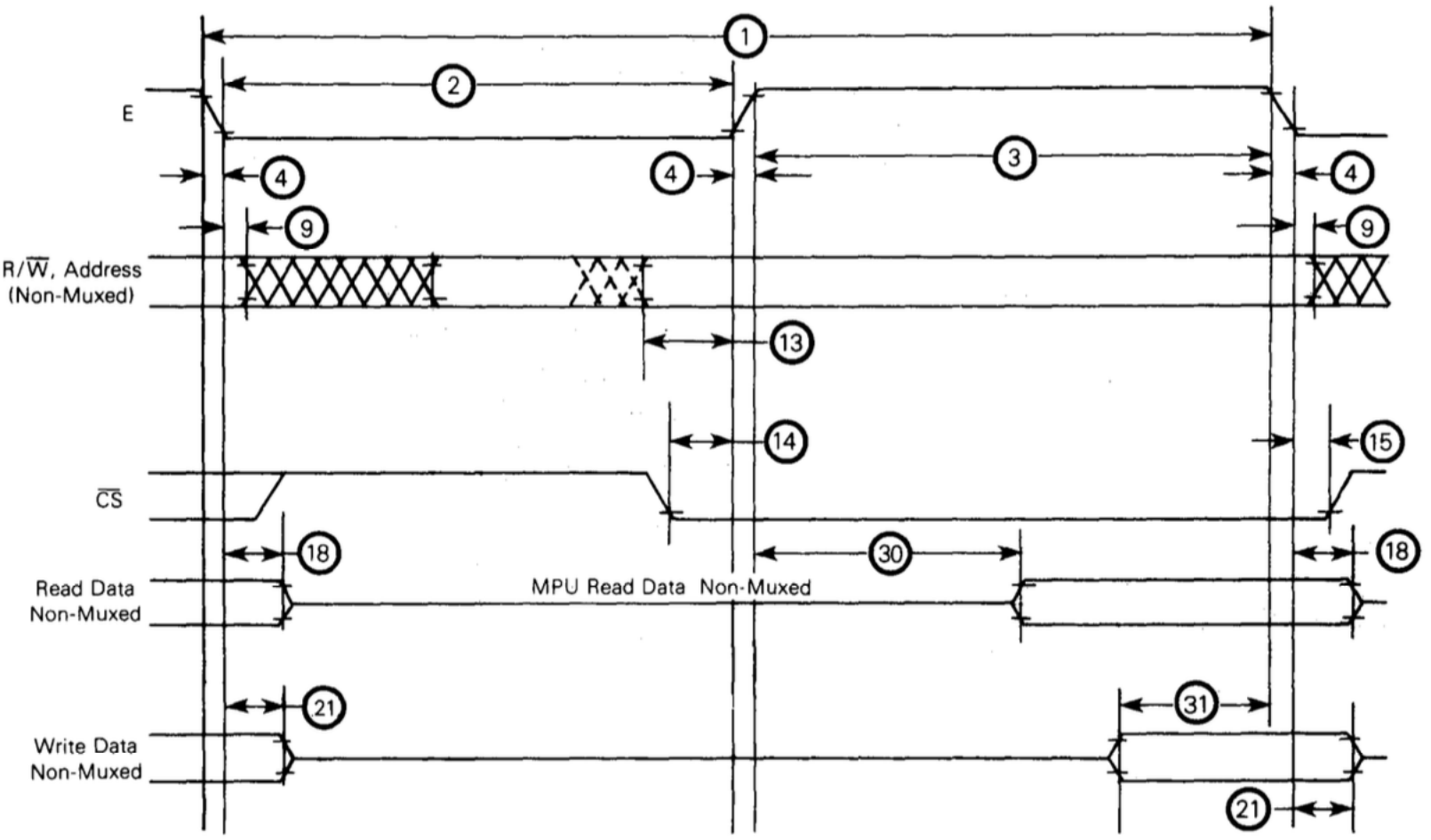

NOTES:

1. Voltage levels shown are $V_L \leq 0.4 V$, $V_H \geq 2.4 V$, unless otherwise specified.
2. Measurement points shown are 0.8 V and 2.0 V, unless otherwise specified.

FIGURE 4 — MODE 1 TIMING
(TSC STEAL MODE)

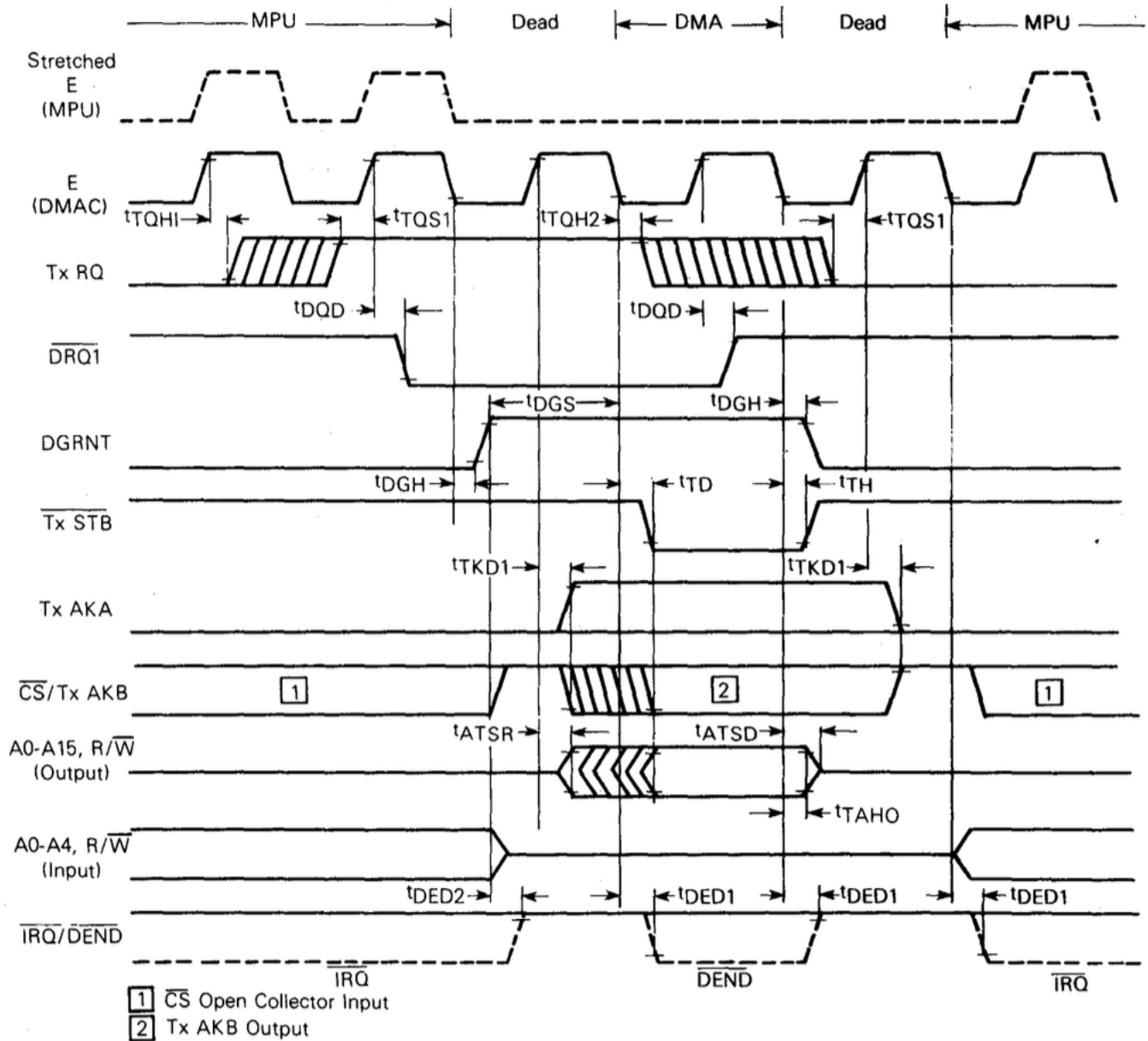

FIGURE 5 — MODE 2 TIMING
(HALT STEAL MODE)

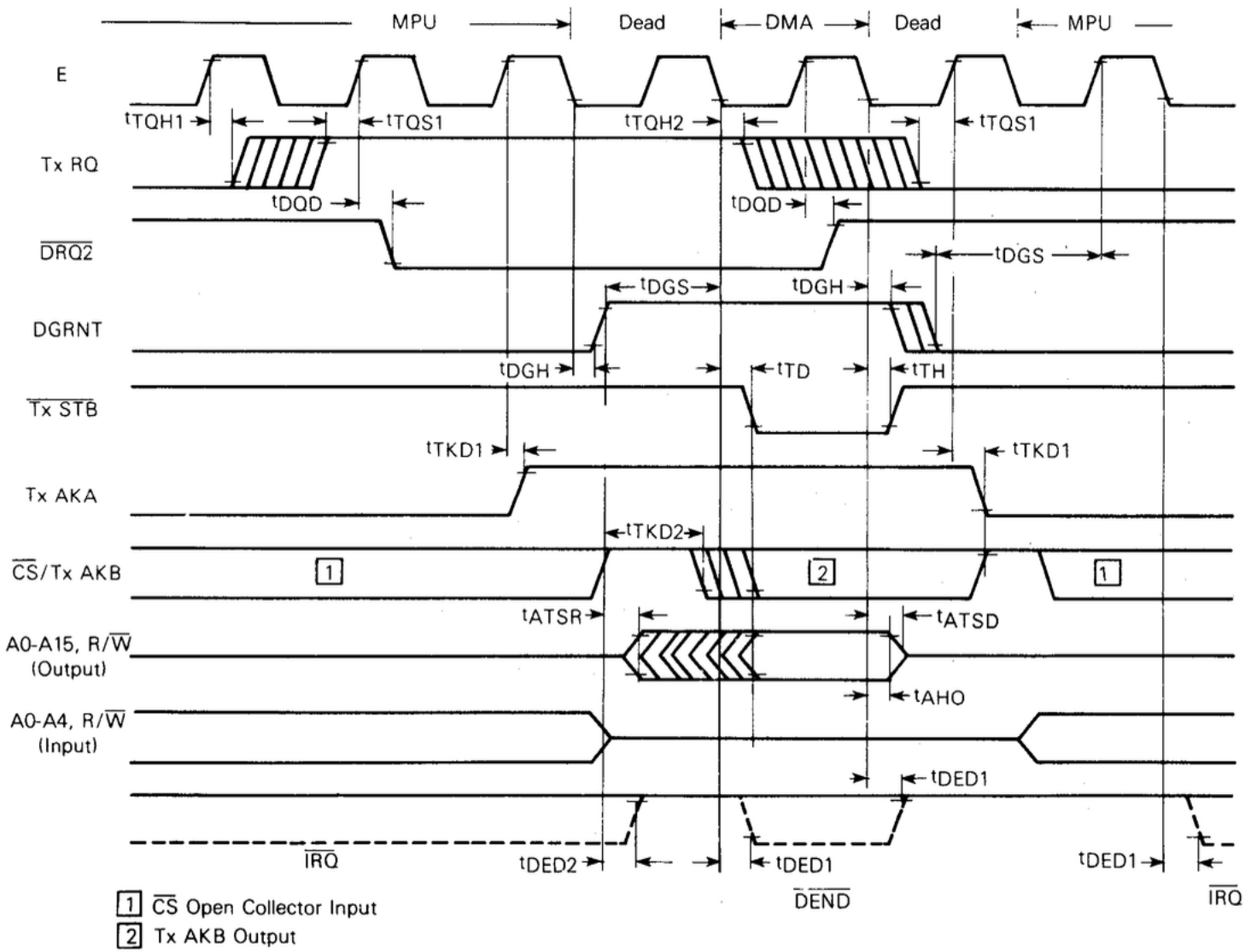
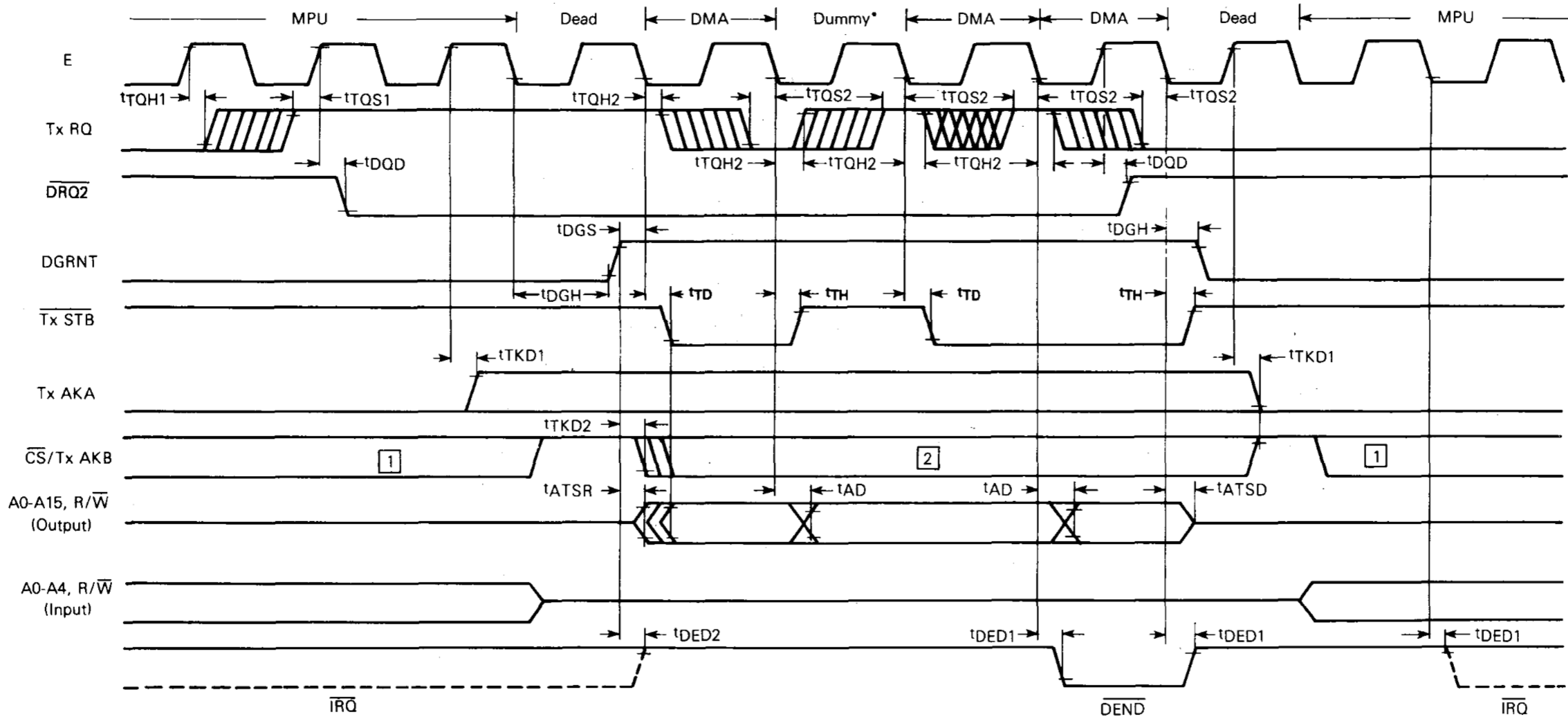

FIGURE 6 — MODE 3 TIMING
(HALT BURST MODE)



- [1] CS Open Collector Input
- [2] Tx AKB Output

*No transfer (dummy cycle) because Tx RQ was negated at start of E cycle.

DMA TIMING (Load Condition Figure 7)

Characteristic	Symbol	MC6844		MC68A44		MC68B44		Unit
		Min	Max	Min	Max	Min	Max	
Tx RQ Setup Time								
E Rising Edge	t_{TQS1}	120	—	120	—	120	—	ns
E Falling Edge	t_{TQS2}	210	—	210	—	170	—	
Tx RQ Hold Time								
E Rising Edge	t_{TQH1}	20	—	10	—	10	—	ns
E Falling Edge	t_{TQH2}	20	—	10	—	10	—	
DGRNT Setup Time	t_{DGS}	155	—	125	—	115	—	ns
DGRNT Hold Time	t_{DGH}	10	—	10	—	10	—	ns
Address Output Delay Time	A0-A15, R/W t_{AD}	—	270	—	180	—	150	ns
Address Output Hold Time	A0-A15, R/W t_{AHO}	30	—	20	—	20	—	ns
Address Three-State Delay Time	A0-A15, R/W t_{ATSD}	—	720	—	460	—	370	ns
Address Three-State Recovery Time	t_{ATSR}	—	430	—	280	—	210	ns
Delay Time	DRQ1, DRQ2 t_{DOD}	—	375	—	250	—	200	ns
Tx AK Delay Time								
E Rising Edge	t_{TKD1}	—	400	—	310	—	250	ns
DGRNT Rising Edge	t_{TKD2}	—	190	—	160	—	145	
IRQ/DEND Delay Time								
E Falling Edge	t_{DED1}	—	300	—	250	—	230	ns
DGRNT Rising Edge	t_{DED2}	—	190	—	160	—	145	
Tx STB Output Delay Time	t_{TD}	—	270	—	180	—	150	ns
Tx STB Output Hold Time	t_{TH}	30	—	20	—	20	—	ns

FIGURE 7 — TEST LOADS

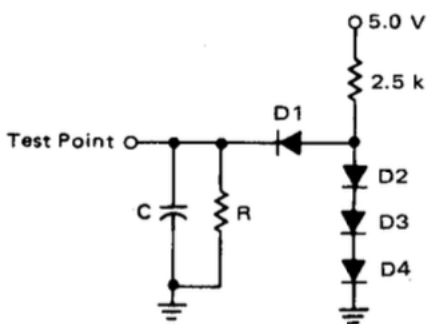

Test Pin	C = pF	R = kΩ
D0-D7	130	11.7
A0-A15, R/W	90	16.5
CS/Tx AKB	50	24
Others	30	24

FIGURE 8 — CS/Tx AKB SOURCE CURRENT TEST CIRCUIT

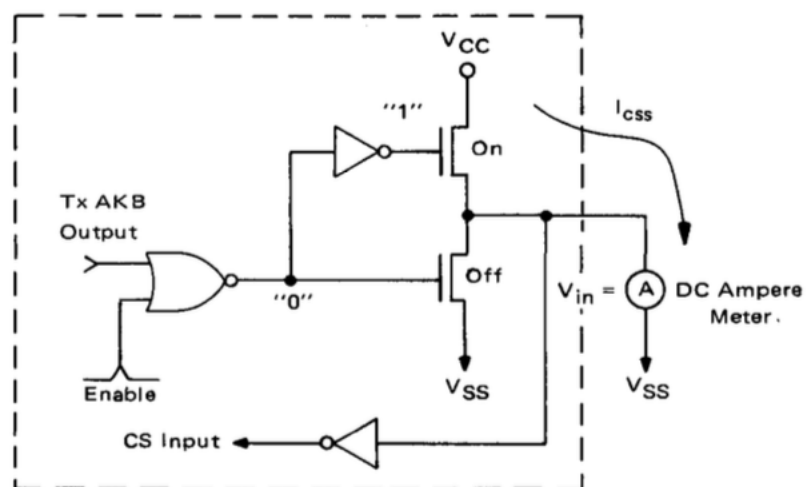

INTRODUCTION

The MC6844 DMAC has four DMA channels which can be independently configured by software using fifteen addressable registers. Eight of the addressable registers are 16-bit registers, and seven are 8-bit registers. Associated with each channel are a 16-bit Address Register, a 16-bit Byte Control Register, and an 8-bit Channel Control Register. The DMAC also has three 8-bit registers which affect all of the channels: the Priority Control Register, the Interrupt Control Register, and the Data Chain Register. A block diagram of the DMAC is presented in Figure 2.

SOFTWARE INITIALIZATION

A channel is initialized for DMA by loading the channel address register with the desired starting DMA address and the channel byte control register with the number of bytes to be transferred. In addition, the channel control register must be initialized for the direction of data transfer, for address register increment or decrement after each byte transfer, and for DMA transfer mode.

Each channel can be initialized for one of three transfer modes: Mode 1, Mode 2, or Mode 3. Two read-only status bits in the channel control register indicate when the channel is busy transferring a block of data and when the DMA transfer of a block of data is complete.

The priority control register, the interrupt control register, and the data chain registers must also be initialized.

The priority control register enables/disables each channel and determines whether channel service requests are serviced in a fixed or a rotating priority. The interrupt control register controls assertion of \overline{IRQ} interrupt by each channel at the end of a data block transfer and sets a flag when \overline{IRQ} is asserted. The data chain register controls selection of two or four channel operation, selection of data chaining operation, and the channel to be updated in the data chaining mode.

When data chaining is enabled, the contents of the channel 3 address and byte count registers are stored into the corresponding registers of the channel selected for chaining after the channel data block transfer is completed. This feature allows for repetitively reading or writing a block of memory.

HARDWARE INITIALIZATION

At power-on reset (POR) and anytime \overline{RESET} is asserted, all device registers except the address and byte count registers are cleared. Therefore, the state of the DMAC after reset is as follows:

- all DMA channels are disabled,
- all interrupts are disabled,
- all flags are cleared,
- address register decrement is selected for each channel,
- mode 2 is selected for each channel,
- peripheral controller write-to-memory is selected for each channel,
- two-channel operation is selected, and
- data chaining is disabled.

DMAC BUS CONTROL

During DMA operation, the DMAC controls the system address and data buses and generates system R/W. The DMAC also generates $\overline{Tx STB}$, which can be used to derive system VMA; Tx AKA and Tx AKB, which can be used to identify which DMA channel is in service; $\overline{DRQ1}$ and $\overline{DRQ2}$, which are used for handshaking with the system MPU; \overline{DEND} , which is asserted when the last byte of a data block is being transferred; and \overline{IRQ} , which when enabled will interrupt the system MPU when a data block transfer is completed. Data itself does not pass through the DMAC, but is transferred between memory and peripheral under control of the DMAC.

TRANSFER MODES

Each DMAC channel can be programmed to operate in one of three modes. * Two of the modes, mode 1 and mode 2, are single-byte transfer modes in which the DMAC returns the bus to the MPU after each DMA transfer by negating the appropriate DMA Request ($\overline{DRQ1}$ or $\overline{DRQ2}$). These modes are intended to be used in applications requiring the MPU to regain control of the bus after each byte transfer. Timing information for modes 1 and 2 is presented in Figures 4 and 5.

Mode 3 is a block transfer mode in which the DMAC retains control of the bus until the last byte of the DMA data block has been transferred (byte control register 0), if \overline{DGRNT} remains asserted during the entire block transfer. In mode 3, byte transfers are possible at the DMAC clock frequency by asserting Tx RQ each cycle. This mode offers the highest DMA transfer rate. Mode 3 timing is presented in Figure 6.

A flowchart of DMAC operation in each mode is presented in Figure 9.

FUNCTIONAL PIN DESCRIPTIONS

VCC AND VSS

VCC and VSS provide power to the DMAC. The power supply should provide +5 V \pm 5% to VCC. VSS should be tied to ground. Total power dissipation will not exceed P_D milliwatts.

RESET

This input is used to place the DMAC into a known state and provide for an orderly startup procedure. Assertion of \overline{RESET} clears all internal registers except the address and the byte count registers (see Hardware Initialization).

E (ENABLE)

This TTL-compatible input is used to clock the DMAC with the MPU E clock. In systems that perform single-byte transfers by stretching the MPU clock rather than by halting the MPU, the system must be designed to provide a non-stretched E clock to this pin. Clock modules such as the MC6875 are available which provide a separate stretchable E clock to externally-driven MPUs and a non-stretched clock to the DMAC.

*Modes 1, 2, and 3 are also called TSC Steal, HALT Steal, and HALT Burst modes.

FIGURE 9 — FLOWCHART OF DMAC OPERATION

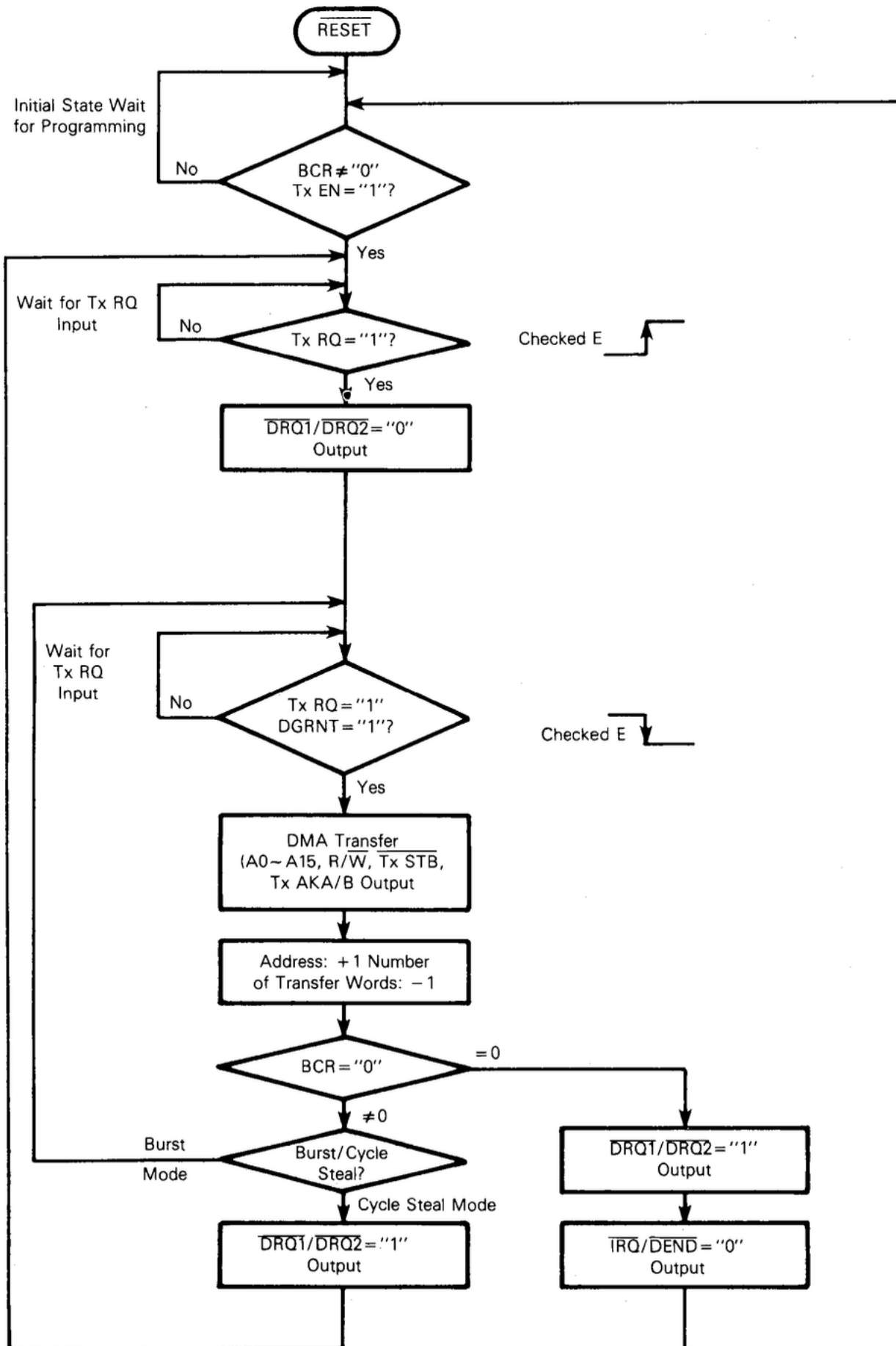

READ/WRITE (R/ \overline{W})

This TTL-compatible bidirectional line is a high-impedance input when the DMAC is off the system bus (MPU mode), and an output when the DMAC is controlling the bus (DMA mode). In the MPU mode, this input is used to control the direction of data transfer through the DMAC data bus interface to allow MPU reads and writes to internal registers. In the DMA mode, Read/Write is an output to the system bus, with its state controlled by bit 0 of the appropriate channel control register.

ADDRESS A0-A15

Address lines A0-A4 are bidirectional. In the MPU mode, these lines are inputs used by the MPU to address DMAC registers. In the DMA mode, these lines and lines A5-A15 are outputs which assert the contents of the address register of the channel being serviced. Address lines A0-A15 are TTL compatible.

DATA D0-D7

These bidirectional TTL-compatible lines are used for data transfer between the MPU and the DMAC. These lines remain in the high-impedance state except when the MPU reads DMAC registers.

INTERRUPT REQUEST/DMA END (\overline{IRQ} / \overline{DEND})

Interrupt Request/DMA End is a TTL-compatible, time-multiplexed, active low output used to interrupt the MPU and signal a peripheral controller when a DMAC data block transfer has ended. \overline{DEND} is asserted during the transfer of the last data byte of a block transfer for one E clock cycle (see Figures 4, 5, and 6). \overline{IRQ} is asserted after the last byte transfer of a block transfer if enabled by setting the proper DEND IRQ enable bit in the interrupt control register (see Table 2). Once asserted, \overline{IRQ} is negated by reading the channel control register of the channel asserting the interrupt.

TRANSFER REQUEST (Tx RQ0-3)

Associated with each channel is a high-impedance input pin used by a peripheral controller to request DMA service by the channel. The Tx RQ pins are sampled by the DMAC in an order of priority determined by the software-programmable state of the priority control register. The Tx RQ pins for channels programmed for mode 1 or mode 2 operation (single-byte transfer modes) are sampled on the rising edge of E. If Tx RQ for one of these channels is asserted when sampled, the DMAC will perform one DMA byte transfer for the channel before sampling the Tx RQ pin of the channel next in the priority. The Tx RQ pins for channels programmed for mode 3 operation (block transfer mode) are sampled on the rising edge of E for the first DMA byte transfer only. If a Tx RQ for one of these channels is asserted when sampled, the first byte of the channel data block is transferred, then the Tx RQ pin is sampled on falling edges of E for subsequent byte transfers (see Figure 6). Once a channel programmed for mode 3 operation begins DMA, that channel has priority of servicing until the channel completes its entire block transfer.

DMA REQUEST 1-2 ($\overline{DRQ1}$, $\overline{DRQ2}$)

These active low TTL-compatible outputs are used by the DMAC to handshake with the MPU in requesting the system bus for DMA operation. $\overline{DRQ1}$ is asserted to indicate that a channel configured for mode 1 operation requires servicing, and $\overline{DRQ2}$ is asserted to indicate that a channel configured for mode 2 or mode 3 operation requires servicing. Once asserted, each output remains asserted until the DMAC completes one DMA byte transfer in mode 1 and mode 2 DMA, or an entire byte block transfer in mode 3 DMA.

DMA GRANT (DGRNT)

This high-impedance input is used to enable MC6844 DMA operation and should be asserted only after the MPU has relinquished the system bus to the DMAC. Typically, DGRNT will be asserted by the MPU in response to a DMA request, indicating that the system bus is available for DMA.

TRANSFER STROBE (Tx STB)

Tx STB is asserted during each DMA transfer cycle and can be used as a transfer acknowledge for peripheral controllers and as a system VMA. Tx STB is a TTL-compatible output.

TRANSFER ACKNOWLEDGE A (Tx AKA)

Transfer Acknowledge A is asserted during DMA operation and can be used with Tx AKB to identify the DMA channel being serviced, as shown in Table 1.

CHIP SELECT/TRANSFER ACKNOWLEDGE B (\overline{CS} /Tx AKB)

This bidirectional pin serves two functions. During MPU operation it is a chip-select input which when asserted allows MPU access to the DMAC registers. During DMA transfers this pin is for Tx AKB output, used with Tx AKA to identify the DMA channel being serviced (see Table 1).

TABLE 1 — ENCODING ORDER

\overline{CS} /Tx AKB	Tx AKA	Channel #
0	0	0
0	1	1
1	0	2
1	1	3

DMAC REGISTERS

All DMAC registers are read/write registers, although some of the register status bits are read-only. Table 2 presents a summary of the DMAC control registers, and Table 3 lists address and byte count register addresses.

ADDRESS REGISTERS

Associated with each DMA channel is an address register which stores the 16-bit address to be asserted on the system

TABLE 2 — DMAC CONTROL REGISTERS

Register	Address (Hex)	Register Content							
		Bit 7	Bit 6	Bit 5	Bit 4	Bit 3	Bit 2	Bit 1	Bit 0
Channel Control	1x*	DMA End Flag (DEND)	Busy/Ready Flag	Not Used	Not Used	Address Up/Down	MCA	MCB	Read/Write (R/W)
Priority Control	14	Rotate Control	Not Used	Not Used	Not Used	Request Enable #3 (RE3)	Request Enable #2 (RE2)	Request Enable #1 (RE1)	Request Enable #0 (RE0)
Interrupt Control	15	DEND IRQ Flag	Not Used	Not Used	Not Used	DEND IRQ Enable #3 (DIE3)	DEND IRQ Enable #2 (DIE2)	DEND IRQ Enable #1 (DIE1)	DEND IRQ Enable #0 (DIE0)
Data Chain	16	Not Used	Not Used	Not Used	Not Used	Two/Four Channel Select (2/4)	Data Chain Channel Select B	Data Chain Channel Select A	Data Chain Enable

*The x represents the binary equivalent of the channel desired.

TABLE 3 — ADDRESS AND BYTE COUNT REGISTERS

Register	Channel	Address (Hex)
Address High	0	0
Address Low	0	1
Byte Count High	0	2
Byte Count Low	0	3
Address High	1	4
Address Low	1	5
Byte Count High	1	6
Byte Count Low	1	7
Address High	2	8
Address Low	2	9
Byte Count High	2	A
Byte Count Low	2	B
Address High	3	C
Address Low	3	D
Byte Count High	3	E
Byte Count Low	3	F

address bus during the next DMA cycle of the channel. After each DMA byte transfer, the address register will increment or decrement according to the state of bit 3 of the appropriate channel control register. The starting address of a DMA data block should be stored in the address register of a channel to be used before beginning DMA operation with the channel.

BYTE COUNT REGISTERS

Each channel has a 16-bit byte count register which stores the number of DMA cycles remaining in a channel DMA block. This register should be loaded with the number of

bytes to be transferred by a channel before the channel begins DMA. The byte count register is decremented at the beginning of a DMA cycle.

CHANNEL CONTROL REGISTERS

A channel control register associated with each channel is used to control the channel mode of operation, the state of the R/W line during DMA, and whether the channel address register will increment or decrement after each DMA cycle. The channel control registers contain two read-only status flags which report the status of the channel. The channel control register bits are defined as follows:

Bit 0 R/W Read/Write. The direction of DMA transfer is determined by the state of this bit. When this bit is a "1", R/W will be asserted high by the DMAC during DMA, and memory will be read by the peripheral controller. When this bit is a "0", R/W will be asserted low by the DMAC during DMA and data transfer will be from the peripheral controller to memory.

Bit 1 MCB Mode Control B. This bit is used to select the channel DMA mode. When this bit is a "1", mode 3 operation is selected. When this bit is clear, either mode 1 or mode 2 operation is selected according to the state of channel control register bit 2. Table 4 shows the DMA mode options.

TABLE 4 — DMA MODE SELECT

MCA	MCB	DMA Transfer Mode
0	0	Mode 2
0	1	Mode 3
1	0	Mode 1
1	1	Undefined

- Bit 2 MCA Mode Control A. This bit is used with MCB to select the channel DMA mode. When MCB is set, this bit must be clear and mode 3 operation is selected. Setting both MCA and MCB to a "1" places the DMAC into an undefined mode of operation. With MCB clear, setting MCA to a "1" places the channel into mode 1 and clearing MCA places the channel into mode 2 (see Table 2).
- Bit 3 Address Up/Down. Bit 3 controls address register increment/decrement during DMA. If this bit is set to a "1", the address register decrements with each DMA cycle; if it is clear, the address register increments with each DMA cycle.
- Bits 4-5 Not used.
- Bit 6 Busy/Ready Flag. The Busy/Ready flag is read-only status bit that indicates a DMA block transfer is in progress in the channel. After initializing the channel for a block transfer (address register, byte count register, etc.), this flag sets when Tx RQ is recognized and clears during the last block byte transfer.
- Bit 7 DEND DMA End Flag (DEND). The DEND flag is used to indicate when a DMA transfer is complete. This flag is set during the transfer of the last byte of a DMA block and is cleared by reading the channel control register. This flag will generate an IRQ interrupt if enabled in the interrupt control register.

PRIORITY CONTROL REGISTER

The Priority Control Register is used to individually enable each DMA channel and to select the channel service priority scheme, with bits defined as follows:

- Bits 0-3 RE0-3 Request Enable 0-3. Each DMA channel is individually enabled by setting the appropriate RE bit (RE0 for channel 0 etc.) in the priority control register. A clear channel RE bit inhibits recognition of Tx RQ for the channel.
- Bits 4-6 Not used.
- Bit 7 Rotate Control. One of two channel service priority schemes can be selected by bit 7. When this bit is "0", the fixed priority of servicing is selected in which channel 0 has highest priority, channel 1 has the next highest priority, channel 2 the next highest priority, and channel 3 the last priority. When this bit is set to a "1", the rotating priority of servicing is selected. Rotating priority is initially the same as fixed priority, in that the lower numbered channels initially have the higher priorities. However, once a channel is serviced in the rotating priority mode, that channel is given last priority of servicing. In this scheme the channel last serviced gets the last priority.

INTERRUPT CONTROL REGISTER

The interrupt control register allows the user to selectively enable each channel $\overline{\text{IRQ}}$ interrupt. When enabled, an IRQ is generated when a DMA block transfer is complete. The interrupt control register also has a flag to indicate that the DMAC $\overline{\text{IRQ}}$ is asserted. Interrupt control register bits are defined as follows:

- Bits 0-3 DIE0-3 DEND IRQ Enable. These bits enable individual channel $\overline{\text{IRQ}}$ interrupts when set to "1", and mask these interrupts when cleared. The register bit number is the same as the channel number controlled by the bit. An $\overline{\text{IRQ}}$ is asserted only when a DMA block transfer is completed.
- Bits 4-6 Not used.
- Bit 7 DEND IRQ Flag. This read-only bit is set to a "1" when the DMAC $\overline{\text{IRQ}}$ is asserted, indicating the end of a channel block transfer (DEND assertion) with interrupt enabled. This flag is cleared and $\overline{\text{IRQ}}$ is negated by a read of the channel control register of the channel causing the $\overline{\text{IRQ}}$ interrupt.

DATA CHAIN REGISTER

Repetitive reading or writing of a block of memory can best be performed using the data chain function. This function transfers the contents of the channel 3 address and byte count registers into the respective registers of the channel selected for data chaining. These contents are transferred during the E cycle following the transfer of the last byte of a block by the selected channel. The data chain register is defined as follows:

- Bit 0 DCE Data Chain Enable. Data chaining is enabled when this bit is set to a "1". When this bit is clear, data chaining is disabled.
- Bit 1-2 DCA/B Data Chain Select A, B. The state of these two bits determine which channel will be updated when data chaining is enabled, as listed in Table 5.
- Bit 3 Two/Four Channel Select. The DMAC will operate with either two channels or four channels, depending on the state of this bit. When this bit is set to a "1", the four-channel mode is selected, and all four channels are selectable. When this bit is clear, the two-channel mode is selected and only channels 0 and 1 are selectable.
- Bits 4-7 Not used.

TABLE 5 — CHANNEL SELECT

DCB Bit 2	DCA Bit 1	Channel #
0	0	0
0	1	1
1	0	2
1	1	Undefined

APPLICATIONS

The MC6844 DMAC can be interfaced to a wide variety of MPUs, including the Motorola MC68000. This section offers examples of MC6844 interface circuits that can be used as starting points in designing the DMAC into a particular system.

IRQ, DEND, Tx AK GENERATION

Derivation of $\overline{\text{IRQ}}$ (Interrupt Request), DEND (DMA End), and Tx AK (Transfer Acknowledge) for one, two, and four-channel DMA is shown in Figure 10. $\overline{\text{IRQ}}$, if enabled, is asserted by the DMA to interrupt the MPU whenever a DMA block transfer is completed. Tx AK is asserted during each DMA cycle and is used to handshake with a peripheral controller each time a DMA byte transfer occurs. DEND is used to handshake with a peripheral controller each time a DMA block transfer is complete.

Each circuit uses DMA GRANT to demultiplex the $\overline{\text{IRQ/DEND}}$ DMAC output to ensure that the system $\overline{\text{IRQ}}$ is asserted at the proper time, only during MCU operation. Whenever DMA GRANT is high, $\overline{\text{IRQ}}$ is negated.

The circuits also generate DEND and Tx AK for the proper channel, gated by Tx STB.

The one-channel DMA mode requires no channel decoding, so for this mode Tx AK is derived from Tx STB directly, and Tx STB is used to demultiplex the $\overline{\text{IRQ/DEND}}$ output for DEND generation.

The two-channel mode circuit is similar to the one-channel circuit, but uses Tx AKA to identify the active channel and generate the appropriate channel signal (see Table 1).

The four-channel circuit is functionally similar to the two-channel circuit but uses a 74LS139 to decode Tx AKA and Tx AKB for channel identification. The DMAC $\overline{\text{CS/Tx AKB}}$ pin is bidirectional during four-channel operation, so an open collector gate must be used to drive $\overline{\text{CS}}$ in order to avoid drive contention.

FIGURE 10 — $\overline{\text{IRQ}}$, DEND, Tx AK GENERATION

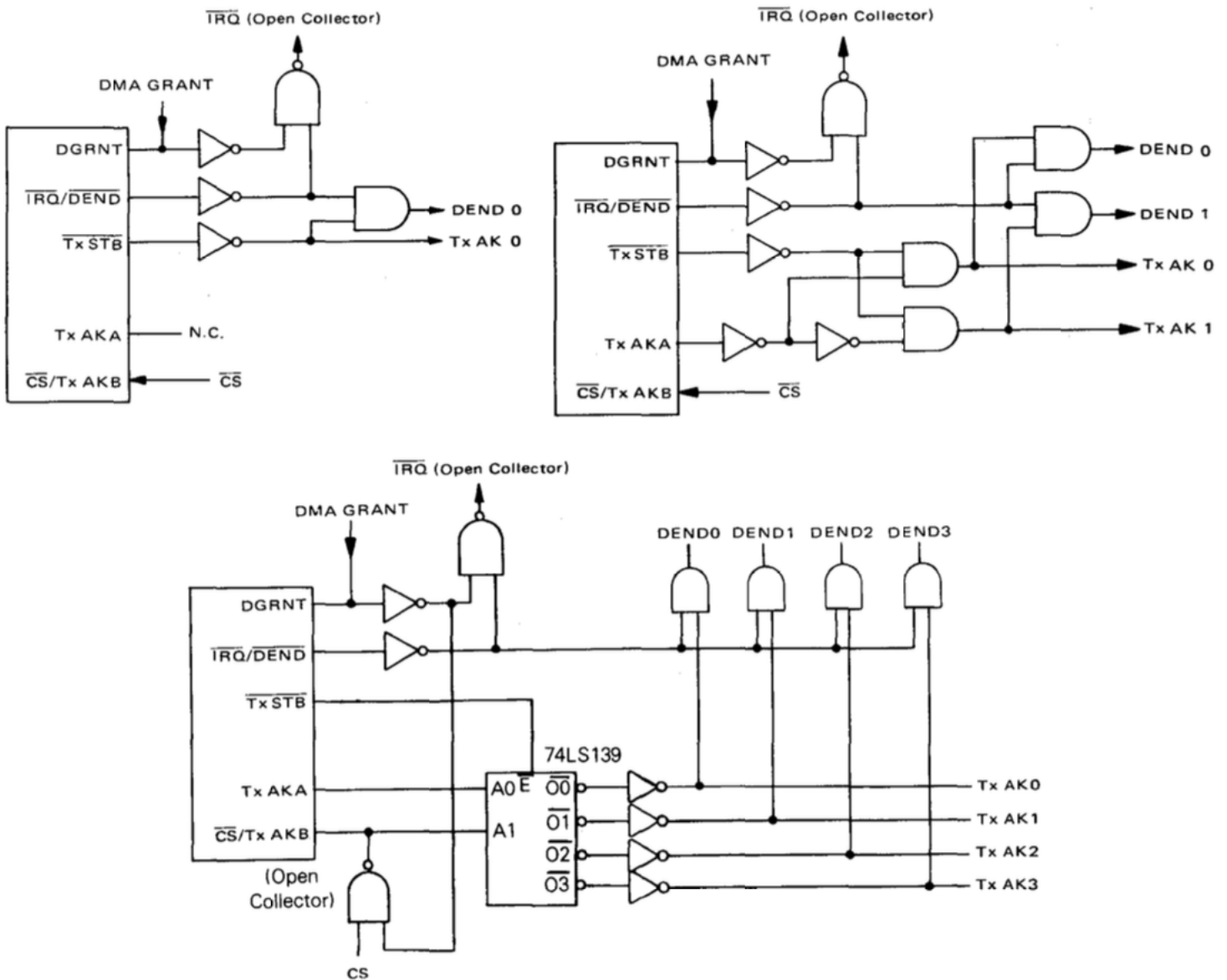

FIGURE 12 — MC6800/MC6844 INTERFACE

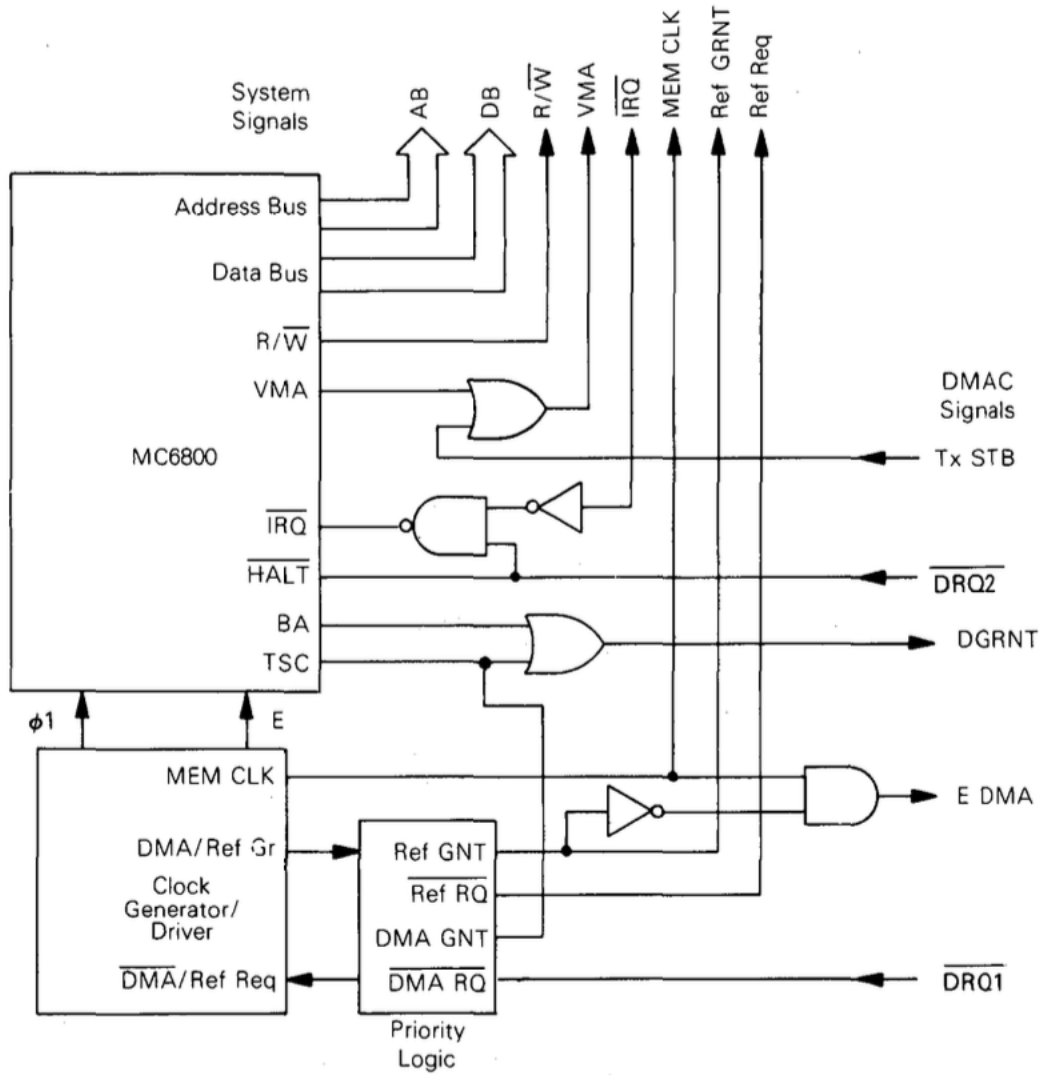
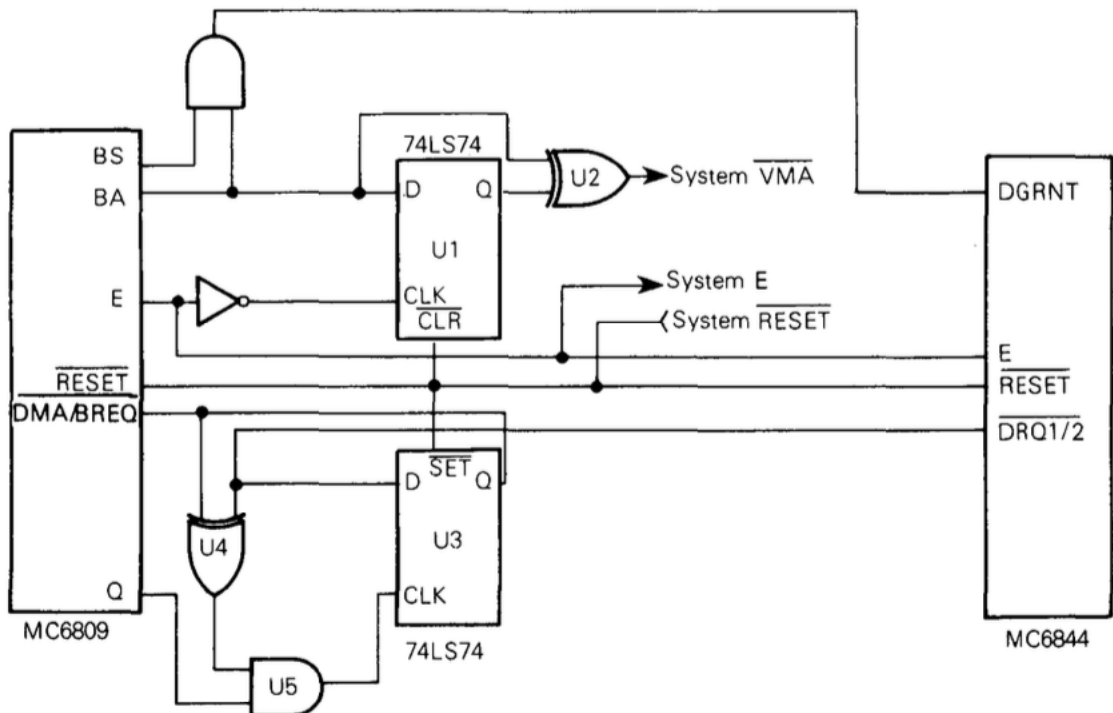

FIGURE 13 — MC6844/MC6809 INTERFACE



MC6844

After the DMA transfer, DRQ1/2 is negated by the MC6844, forcing the output of U4 to a high. Once again, U3 will be clocked only when the MC6809 Q output is high.

VMA is generated by U1 and U2. Initially, in the MPU mode, U1 is clear, with a low Q output. The BA (bus available) output of the MC6809 is also a low. Therefore, the output of U2 (\overline{VMA}) is low (\overline{VMA} asserted). When the MC6809 asserts BA for DMA, the output of U2 becomes

high, indicating that the address on the system address bus is invalid during this dead cycle between MPU and DMA modes. On the next falling edge of E, U1 is clocked high forcing the output of U2 low during this DMA cycle. When BA is negated after DMA, the output of U2 is forced high until the next falling edge of E, indicating invalid address during this dead cycle.

ORDERING INFORMATION

Package Type	Frequency (MHz)	Temperature	Order Number
Ceramic L Suffix	1.0	0°C to 70°C	MC6844L
	1.0	-40°C to 85°C	MC6844CL
	1.5	0°C to 70°C	MC68A44L
	1.5	-40°C to 85°C	MC68A44CL
	2.0	0°C to 70°C	MC68B44L
Cerdip S Suffix	1.0	0°C to 70°C	MC6844S
	1.0	-40°C to 85°C	MC6844CS
	1.5	0°C to 70°C	MC68A44S
	1.5	-40°C to 85°C	MC68A44CS
	2.0	0°C to 70°C	MC68B44S
Plastic P Suffix	1.0	0°C to 70°C	MC6844P
	1.0	-40°C to 85°C	MC6844CP
	1.5	0°C to 70°C	MC68A44P
	1.5	-40°C to 85°C	MC68A44CP
	2.0	0°C to 70°C	MC68B44P