



MOTOROLA

MCM6810
(1.0 MHz)
MCM68A10
(1.5 MHz)
MCM68B10
(2.0 MHz)

128 x 8-BIT STATIC RANDOM ACCESS MEMORY

The MCM6810 is a byte-organized memory designed for use in bus-organized systems. It is fabricated with N-channel silicon-gate technology. For ease of use, the device operates from a single power supply, has compatibility with TTL and DTL, and needs no clocks or refreshing because of static operation.

The memory is compatible with the M6800 Microcomputer Family, providing random storage in byte increments. Memory expansion is provided through multiple Chip Select inputs.

- Organized as 128 Bytes of 8 Bits
- Static Operation
- Bidirectional Three-State Data Input/Output
- Six Chip Select Inputs (Four Active Low, Two Active High)
- Single 5-Volt Power Supply
- TTL Compatible
- Maximum Access Time = 450 ns — MCM6810
360 ns — MCM68A10
250 ns — MCM68B10

MOS
(N-CHANNEL, SILICON-GATE)

**128 x 8-BIT STATIC
RANDOM ACCESS
MEMORY**



P SUFFIX
PLASTIC PACKAGE
CASE 709

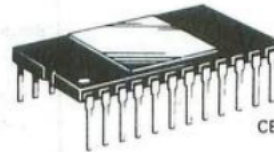

L SUFFIX
CERAMIC PACKAGE
CASE 716



S SUFFIX
CERDIP PACKAGE
CASE 623

MCM6810 RANDOM ACCESS MEMORY BLOCK DIAGRAM

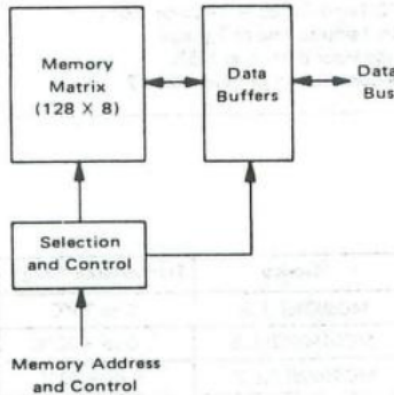

MC6800 Microprocessor M6800 MICROCOMPUTER FAMILY BLOCK DIAGRAM

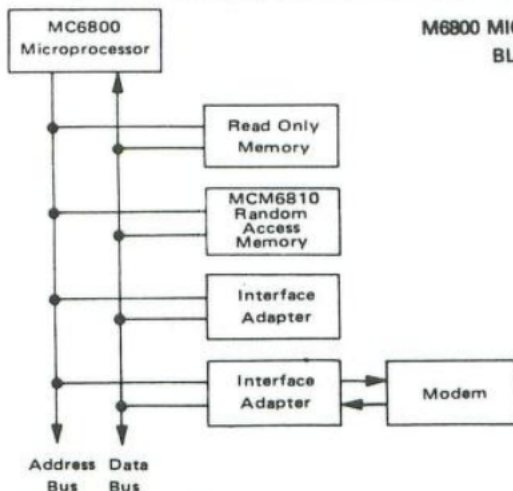

PIN ASSIGNMENT

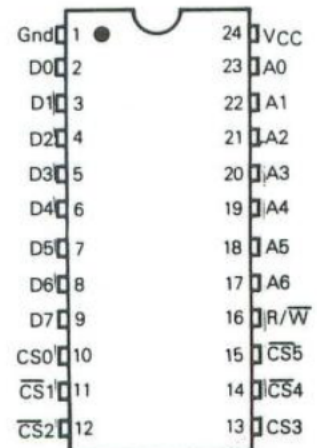

MAXIMUM RATINGS

Rating	Symbol	Value	Unit
Supply Voltage	V_{CC}	-0.3 to +7.0	V
Input Voltage	V_{in}	-0.3 to +7.0	V
Operating Temperature Range MCM6810, MCM68A10, MCM68B10 MCM6810C, MCM68A10C	T_A	T_L to T_H 0 to +70 -40 to +85	°C
Storage Temperature Range	T_{stg}	-65 to +150	°C

This device contains circuitry to protect the inputs against damage due to high static voltages or electric fields; however, it is advised that normal precautions be taken to avoid application of any voltage higher than maximum rated voltages to this high impedance circuit. Reliability of operation is enhanced if unused inputs are tied to an appropriate logic voltage (e.g., either V_{SS} or V_{CC}).

THERMAL CHARACTERISTICS

Characteristics	Symbol	Value	Unit
Thermal Resistance			
Ceramic	θ_{JA}	60	°C/W
Plastic		120	
Cerdip		65	

POWER CONSIDERATIONS

The average chip-junction temperature, T_J , in °C can be obtained from:

$$T_J = T_A + (P_D \cdot \theta_{JA}) \tag{1}$$

Where:

T_A = Ambient Temperature, °C

θ_{JA} = Package Thermal Resistance, Junction-to-Ambient, °C/W

$P_D = P_{INT} + P_{PORT}$

$P_{INT} = I_{CC} \times V_{CC}$, Watts — Chip Internal Power

P_{PORT} = Port Power Dissipation, Watts — User Determined

For most applications $P_{PORT} \ll P_{INT}$ and can be neglected. P_{PORT} may become significant if the device is configured to drive Darlington bases or sink LED loads.

An approximate relationship between P_D and T_J (if P_{PORT} is neglected) is:

$$P_D = K + (T_J + 273^\circ\text{C}) \tag{2}$$

Solving equations 1 and 2 for K gives:

$$K = P_D \cdot (T_A + 273^\circ\text{C}) + \theta_{JA} \cdot P_D^2 \tag{3}$$

Where K is a constant pertaining to the particular part. K can be determined from equation 3 by measuring P_D (at equilibrium) for a known T_A . Using this value of K the values of P_D and T_J can be obtained by solving equations (1) and (2) iteratively for any value of T_A .

DC ELECTRICAL CHARACTERISTICS ($V_{CC} = 5.0$ Vdc $\pm 5\%$, $V_{SS} = 0$, $T_A = T_L$ to T_H unless otherwise noted)

Characteristic	Symbol	Min	Max	Unit
Input High Voltage	V_{IH}	$V_{SS} + 2.0$	V_{CC}	V
Input Low Voltage	V_{IL}	$V_{SS} - 0.3$	$V_{SS} + 0.8$	V
Input Current (A_n , R/\bar{W} , \overline{CS}_n) ($V_{in} = 0$ to 5.25 V)	I_{in}	—	2.5	μA
Output High Voltage ($I_{OH} = -205 \mu\text{A}$)	V_{OH}	2.4	—	V
Output Low Voltage ($I_{OL} = 1.6 \text{ mA}$)	V_{OL}	—	0.4	V
Output Leakage Current (Three-State) ($CS = 0.8$ V or $\overline{CS} = 2.0$ V, $V_{out} = 0.4$ V to 2.4 V)	I_{TSI}	—	10	μA
Supply Current ($V_{CC} = 5.25$ V, All Other Pins Grounded)	I_{CC}	—	80	mA
			100	
Input Capacitance (A_n , R/\bar{W} , CS_n , \overline{CS}_n) ($V_{in} = 0$, $T_A = 25^\circ\text{C}$, $f = 1.0$ MHz)	C_{in}	—	7.5	pF
Output Capacitance (D_n) ($V_{out} = 0$, $T_A = 25^\circ\text{C}$, $f = 1.0$ MHz, $CS_0 = 0$)	C_{out}	—	12.5	pF

BLOCK DIAGRAM

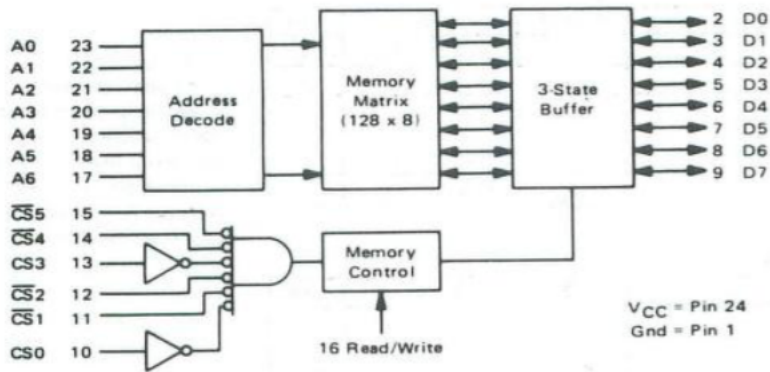

AC OPERATING CONDITIONS AND CHARACTERISTICS

READ CYCLE ($V_{CC} = 5.0 \text{ V} \pm 5\%$, $V_{SS} = 0$, $T_A = T_L$ to T_H unless otherwise noted.)

Characteristic	Symbol	MCM6810		MCM68A10		MCM68B10		Unit
		Min	Max	Min	Max	Min	Max	
Read Cycle Time	$t_{cyc}(R)$	450	—	360	—	250	—	ns
Access Time	t_{acc}	—	450	—	360	—	250	ns
Address Setup Time	t_{AS}	20	—	20	—	20	—	ns
Address Hold Time	t_{AH}	0	—	0	—	0	—	ns
Data Delay Time (Read)	t_{DDR}	—	230	—	220	—	180	ns
Read to Select Delay Time	t_{RCS}	0	—	0	—	0	—	ns
Data Hold from Address	t_{DHA}	10	—	10	—	10	—	ns
Output Hold Time	t_H	10	—	10	—	10	—	ns
Data Hold from Read	t_{DHR}	10	80	10	60	10	60	ns
Read Hold from Chip Select	t_{RH}	0	—	0	—	0	—	ns

READ CYCLE TIMING

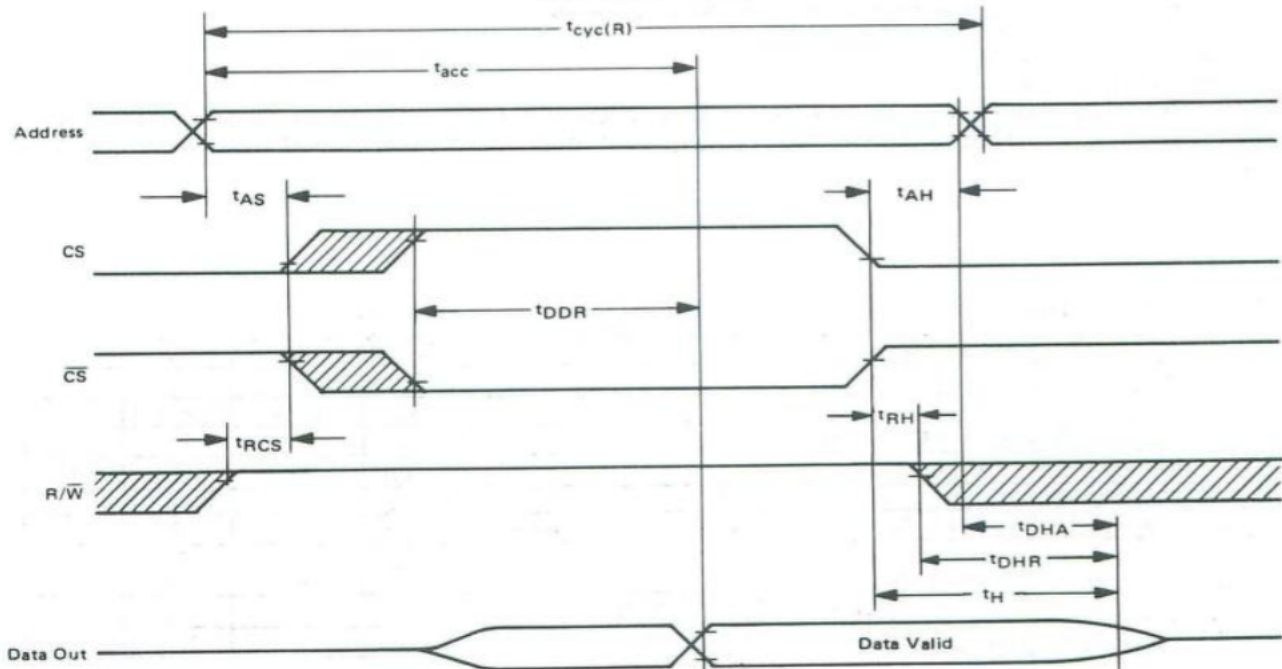

NOTES:

1. Voltage levels shown are $V_L \leq 0.4 \text{ V}$, $V_H \geq 2.4 \text{ V}$, unless otherwise specified.
2. Measurement points shown are 0.8 V and 2.0 V, unless otherwise specified.
3. CS and $\overline{\text{CS}}$ have same timing.

= Don't Care

WRITE CYCLE ($V_{CC} = 5.0\text{ V} \pm 5\%$, $V_{SS} = 0$, $T_A = T_L$ to T_H unless otherwise noted.)

Characteristic	Symbol	MCM6810		MCM68A10		MCM68B10		Unit
		Min	Max	Min	Max	Min	Max	
Write Cycle Time	$t_{cyc(W)}$	450	—	360	—	250	—	ns
Address Setup Time	t_{AS}	20	—	20	—	20	—	ns
Address Hold Time	t_{AH}	0	—	0	—	0	—	ns
Chip Select Pulse Width	t_{CS}	300	—	250	—	210	—	ns
Write to Chip Select Delay Time	t_{WCS}	0	—	0	—	0	—	ns
Data Setup Time (Write)	t_{DSW}	190	—	80	—	60	—	ns
Input Hold Time	t_H	10	—	10	—	10	—	ns
Write Hold Time from Chip Select	t_{WH}	0	—	0	—	0	—	ns

WRITE CYCLE TIMING

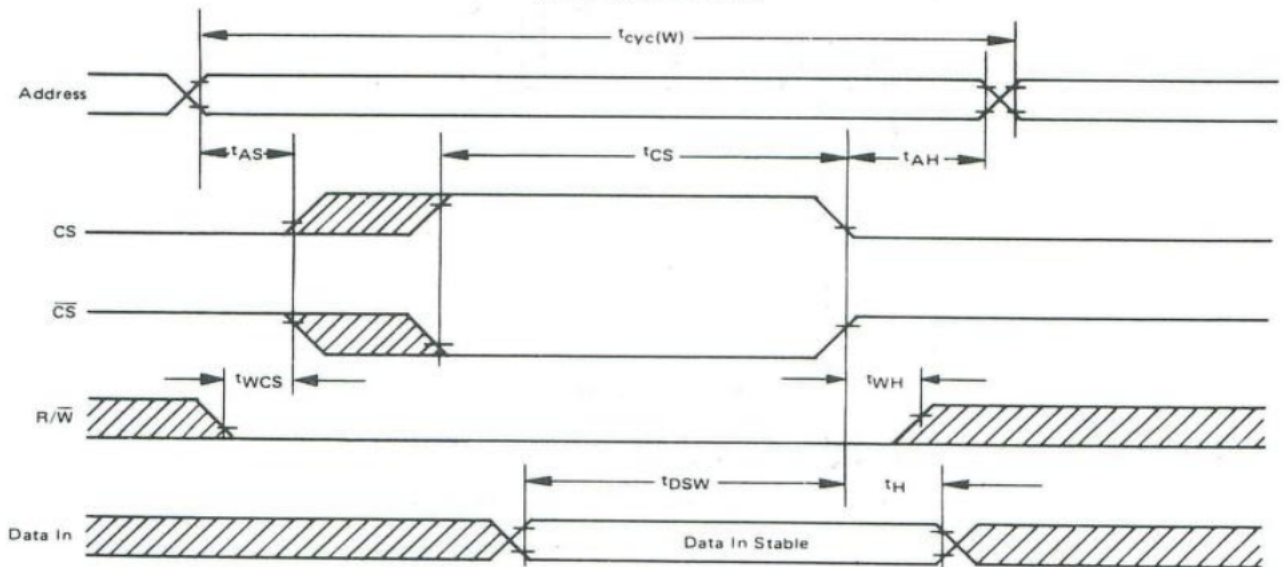

NOTES:

1. Voltage levels shown are $V_L \leq 0.4\text{ V}$, $V_H \geq 2.4\text{ V}$, unless otherwise specified.
2. Measurement points shown are 0.8 V and 2.0 V, unless otherwise specified.
3. CS and CS-bar have same timing.

= Don't Care

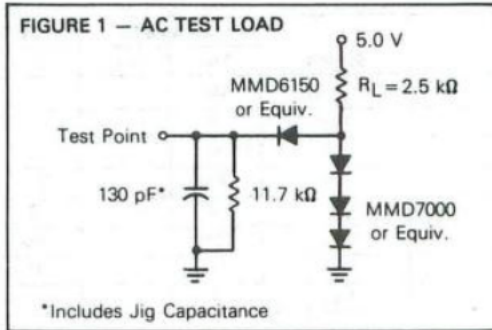

ORDERING INFORMATION

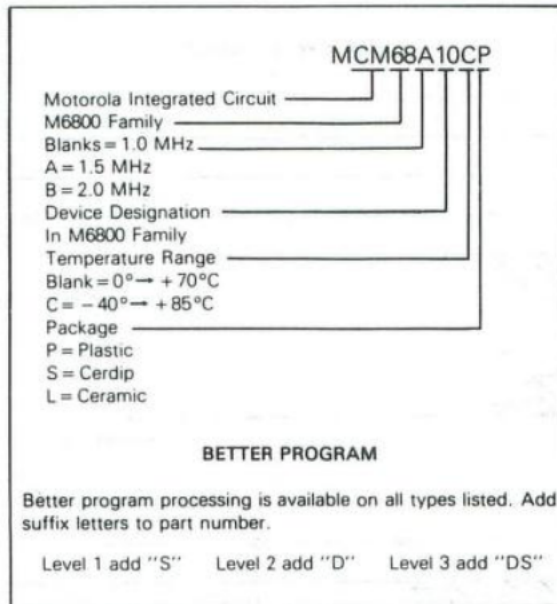

Level 1 "S" = 10 Temp Cycles - (-25 to 150°C);
Hi Temp testing at T_A max.
Level 2 "D" = 168 Hour Burn-in at 125°C
Level 3 "DS" = Combination of Level 1 and 2.

Speed	Device	Temperature Range
1.0 MHz	MCM6810P,L,S	0 to +70°C
	MCM6810CP,CL,CS	-40 to +85°C
1.5 MHz	MCM68A10P,L,S	0 to +70°C
	MCM68A10CP,CL,CS	-40 to +85°C
2.0 MHz	MCM68B10P,L,S	0 to +70°C